

CapTel 800i[®]

How-to Guide



 Ultratec[®]

305-016603 4/10

CapTel 800i Specifications

Physical Dimensions

Size: 9" x 6.5" x 7.5"

Weight: 2 lb. 10oz.

Power

AC Adapter: 6 VDC, 1670 mA

(barrel is negative)

Adapter is UL/CSA listed.

Dial Pad

Large Keys: 0.75" x 0.70"

Display

Backlit, graphical LCD color

display

320 x 240 pixels

Function Buttons

3 Programmable Speed Dial

1 Customer Service Speed Dial

Redial

Flash

Mute

Tone

Caption

Volume

Up/Down/Yes/No

Controls

Conversation: Amplification

when Captions on: 0-40 dB gain

when Captions off: 0-18 dB gain

Tone

Ringer: off, low, medium, high

(0-95 dB)

Indicator Lights

Mute

Volume Levels (1 through 12)

Captions On/Off

Handset

Type: HAC (Hearing Aid

Compatible)

Dialing

Phone Book (97 entries)

Speed Dial (3 entries)

Redial (Last 10 dialed numbers)

Connections

Telephone line: requires RJ11

connection (can be standard

analog line, VOIP, DSL, FIOS.

Does not support digital PBX

system unless analog port

available).

3.5 mm Neckloop/Headset

2.5 mm Headset with microphone

Ethernet

AC power

Approvals

FCC approved

FCC registration number:

US:D8KMM06BCAPTEL800

REN: 0.6B

Conversation Memory

Approximately 480 lines of text

CapTel is the latest innovation from  Ultratec.

Ultratec, Inc.

450 Science Drive

Madison, WI 53711

(888) 269-7477 V/TTY

(866) 670-9134 (Spanish CapTel Customer Service)

Email: CapTel@CapTel.com

Fax: (608) 204-6167

Web: www.CapTel.com

©2009, 2010 Ultratec, Inc. All rights reserved.

Ultratec and CapTel are registered trademarks of Ultratec, Inc.

Congratulations on Choosing *CapTel*!

Welcome to the Captioned Telephone – *CapTel*! With *CapTel*, you can see captions of everything people say over the phone, letting you enjoy calls with confidence.

Please take a moment to read this guide and learn:







- How to start using your *CapTel* phone
- How your *CapTel* phone works
- How to get help when you have questions

We want the *CapTel* phone to be enjoyable and convenient for you. As you use your new phone, we welcome your questions and comments. If we can help, please call – you can even call using your new *CapTel* phone.

Sincerely,

CapTel Customer Service
1-888-269-7477
www.CapTel.com

T A B L E O F C O N T E N T S

	Congratulations on Choosing <i>CapTel</i>	1
	Overview – How <i>CapTel</i> Works	4
	Section 1: Getting Started	5
	What is in the box	5
	Overview of <i>CapTel</i> 800i phone	6
	Using a headset or neckloop (optional).....	11
	Setting up your <i>CapTel</i> 800i	12
	Getting help	16
	Section 2: Making and Answering Calls	17
	Dialing a phone number directly.....	18
	Calling using the Speed Dial buttons	19
	Calling a number in the Phone Book.....	20
	Answering an incoming call.....	21
	Turning captions on/off during a call	22
	Adjusting the volume.....	22
	Adjusting the sound – TONE	23
	Knowing what sounds are on the line.....	24
	Section 3: Viewing Captions	25
	Turning captions on/off during a call	26
	Reviewing captions during a call	26
	Reviewing captions after hanging up.....	27
	Saving conversations.....	28
	Deleting all conversations.....	29
	Changing the caption font size.....	31
	Setting the color of the captions.....	33
	Adjusting the brightness of the Display Screen	35
	Section 4: Call History	37
	Using Call History to see recent calls.....	38
	Clearing all Caller ID entries	40

Section 5: Using the Phone Book	41
Adding a new contact to your Phone Book	42
Dialing a phone number from the Phone Book	44
Editing an existing contact in the Phone Book	45
Removing a contact from your Phone Book	47
Section 6: Using Speed Dial Buttons	48
About the Speed Dial buttons	48
Saving phone numbers in the Speed Dial buttons	49
Editing phone numbers in the Speed Dial buttons	50
Dialing with the Speed Dial buttons	51
Section 7: Seeing Captions of Your Answering Machine and Voice Mail Messages	52
Seeing captions of your Answering Machine messages	53
Connecting an external Answering Machine	54
Seeing captions of your Voice Mail messages	55
Section 8: Telephone Settings	57
Setting the Captions Default to on/off	58
Adjusting the volume of the Ringer	60
Setting the pitch of the Ringer	61
Turning the Ringer switch on/off	62
Setting your <i>CapTel</i> phone for Tone/Pulse dialing	63
Turning on Spanish captions	64
Turning keypad lights on/off	66
Using Call Waiting	67
Dialing 911 with your <i>CapTel</i> 800i	68
Updating your <i>CapTel</i> phone	69
Problem Solving	70
Care and Safety	73
Index	74

How *CapTel* Works

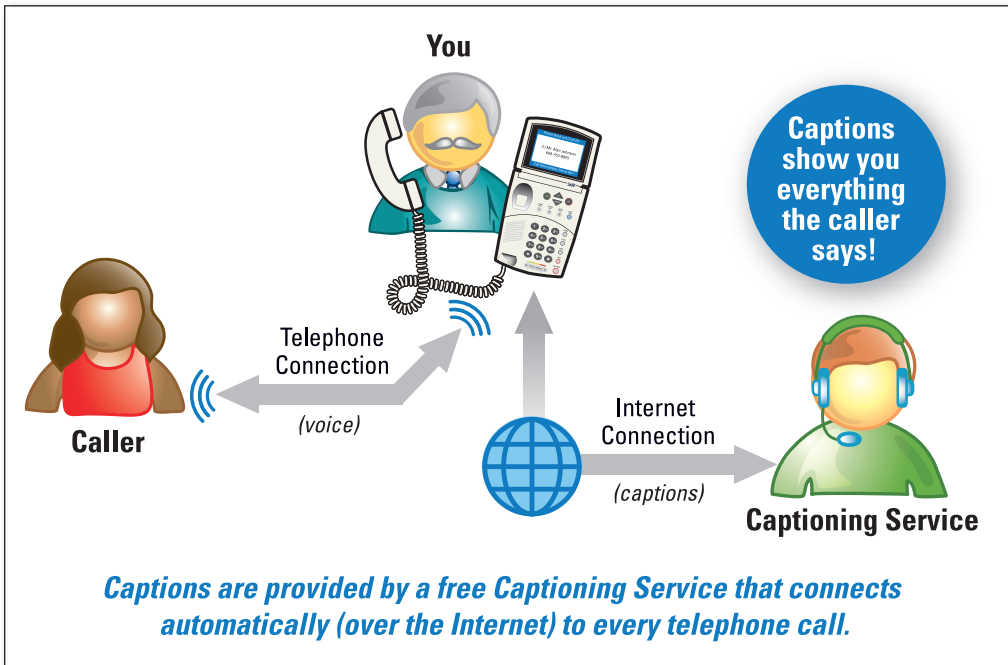

The *CapTel* 800i connects to both your telephone service and to your Internet service. Every time you make a telephone call, the phone automatically connects to a free Captioning Service over the Internet. An operator at the Captioning Service uses voice recognition technology to generate captions of everything your caller says, and sends the captions back to your *CapTel* 800i phone.

You can enjoy conversations over the phone with the added help of written captions in case you miss anything.

NOTE: *The CapTel 800i phone does not generate captions of the phone call on its own. The phone works with the Captioning Service (over the Internet) to display captions during your calls.*

Getting Started

This section explains how to start using your new CapTel 800i phone.

TOPICS:

- **What is in the Box**
- **Overview of *CapTel* 800i Phone**
- **Using a Headset or Neckloop (Optional)**
- **Setting up your *CapTel* 800i**

What is in the Box?

Your *CapTel* 800i includes the following parts:



- *CapTel* 800i Phone

- Telephone Cord



- Power Adapter – to plug into a wall outlet

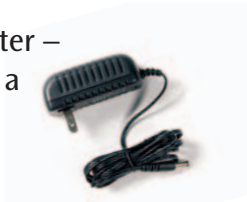

- Ethernet Cable – to connect to Internet service



- *CapTel* Installation Guide and *CapTel* How-to Guide



- Warranty Card



Overview of *CapTel* 800i Phone



1. Display Screen

Shows captions, Caller ID, Phone Book entries and more.



2. YES Button

Allows you to select items that are highlighted in the Options list, and respond “Yes” to questions or commands on the display screen.



3. NO (Exit) Button

Allows you to respond “No” to questions or commands on the display screen and to Exit out of the Options list.



4. UP (Back) Button

Allows you to move up through items in the Options list and move through entries in your Phone Book or Call History. Also lets you go back to review captions that have already scrolled off the display screen.



4. DOWN (More) Button

Allows you to move down through items in the Options list and move through entries in your Phone Book or Call History. Also lets you scroll down through captions when reviewing calls.

CUST
SERV



5. CUSTOMER SERVICE Button

Our helpful customer service team is happy to help you set up and use your *CapTel* 800i telephone – we’re only a button push away. Pressing the CUST SERV button will automatically dial the *CapTel* help line. In an office, you may need to dial 9 first.

NOTE: *On-demand help is available during standard business hours, Monday through Friday, from 8:00am – 5:00pm CST. Help materials are also available online anytime at www.CapTel.com.*

SPEED
DIAL



SPEED
DIAL



SPEED
DIAL



6. SPEED DIAL Buttons

You can quickly dial up to three frequently-called phone numbers, just by pressing a speed dial button.

REDIAL



7. REDIAL Button

Lets you dial up to 10 most-recently called phone numbers. Lift the handset and press REDIAL button to dial the last phone number called. Leave the handset down and press the REDIAL button to review/dial up to the last 10 numbers called.

FLASH



8. FLASH Button

Some telephone service features like Call Waiting require a “hook flash.” The hook flash is a very brief interruption of the connection like hanging up the phone for one second. There is a brief click or silence on the line.

MUTE



9. MUTE Button

Silences the sound from your end of the conversation. When the MUTE button is pressed (red light around the button is ON), the person on the other end of your call will not be able to hear you. You will still be able to hear the caller and get captions of everything they say. To turn the Mute feature off, press the MUTE button again (red light around the button is OFF).

TONE



10. TONE Button

Allows you to adjust the sound settings of the call, letting you enhance LOW, MED, or HIGH frequency tones to find the range that you hear best.

CAPTIONS



11. CAPTIONS Button

To see captions during your call, make sure the red light around the CAPTIONS button is on. Your call will automatically be connected over the Internet to the free service that provides the captions. Captions can be turned on or off at any time during a call. To turn the captions off, just press the CAPTIONS button to turn the red light off.



12. VOLUME Bar

Lets you adjust the volume to a comfortable level, up to a 40 dB gain from min/max for captioned calls. To increase the volume, press the ▲ right side of the VOLUME bar. To decrease the volume, press the ▼ left side of the VOLUME bar. There are 12 volume levels. Watch the light panel above the VOLUME bar to know what the current volume setting is.

WARNING: *The maximum volume setting on captioned calls is extremely loud. People who do not need amplification should not use the phone at the highest volume setting. The volume level automatically returns to a mid-range setting whenever the phone is hung up.*

Back (top) edge view of *CapTel 800i*

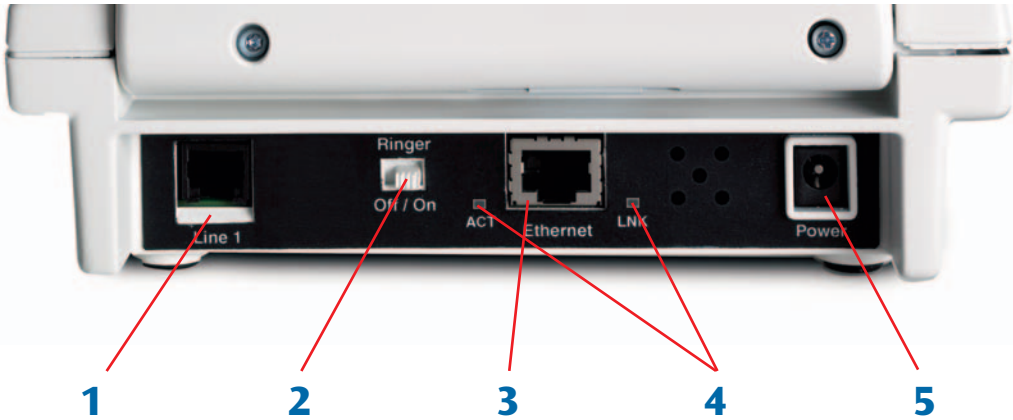

Features

1. Telephone Line

Plug the telephone cord here (RJ11 jack). Phone cord can be for analog, VOIP, FIOS, Digital Cable service, or analog with DSL service. Does not work with PBX system, unless an analog port is available.

2. Ringer switch (ON/OFF)

Turns audible Ringer on/off.

3. Ethernet Jack

Plug Ethernet cable (provided) here to connect to your Internet Service.

4. Ethernet Status Lights

Lets you know if you are connected to the Internet and whether activity is on the line.

5. Power Jack

Plug AC power adapter here.

Using a Headset or Neckloop (Optional)

Audio Jacks (2.5 mm/3.5 mm)

You can use earphones, a headset, neckloop, or other type of listening device with the *CapTel* 800i to maximize the audio quality or to enjoy your new phone hands-free. Open the protective cover to reach the jacks. Simply plug the headset/assistive device into the appropriate 2.5 mm or 3.5 mm audio jack located on the right edge of the *CapTel* 800i phone.

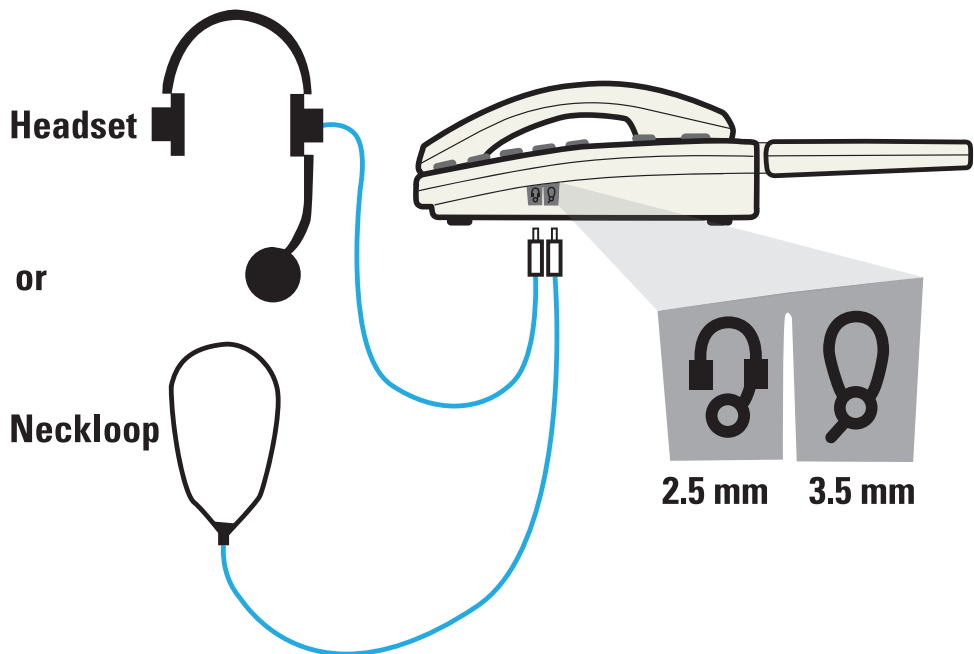

Setting up Your *CapTel* 800i

For complete instructions, please see the Installation Guide.

Requirements

1. High-speed Internet access using a DSL or Digital Cable modem (must connect to an available Ethernet jack). Depending on your set-up, a Router may also be required to connect more than one device to your Internet service.
2. Telephone service (can be analog line, VOIP, FIOS, or Digital Cable phone service).
3. Standard electrical power (AC adapter plugs into standard wall outlet).

Select a location

Set up the *CapTel* 800i in a place where:

- There is a high-speed Internet (Ethernet) jack or your home router is located nearby.
- There is a telephone jack nearby (can be analog line, VOIP, FIOS, or Digital Cable phone service).
- There is an electrical outlet nearby.
- The surface it will be set on, or mounted to, is stable and secure.
- The area is protected from excessive heat or humidity.

NOTE: *The outlets for power, the phone line, and the Ethernet connection should all be located nearby, as each cord needs to plug into your CapTel 800i. If your Internet access is located in a different room than where you plan to use the CapTel 800i, see the Installation Guide or contact CapTel Customer Service for help.*

Connect to a power outlet

1. Plug the power adapter in the power socket labeled “Power” located on the back (top) edge of the *CapTel* 800i.
2. Plug the power adapter into a wall outlet or power strip. The *CapTel* display screen will light up to let you know power is connected.

TIP: Plug your power adapter into an electrical power surge protector to protect your *CapTel* 800i from damage caused by unspecified electrical voltage or damage caused by lightning.

Connect to your telephone service

1. Plug one end of the telephone cord into the telephone jack labeled “Line 1” located on the back (top) edge of the *CapTel* 800i. (Use the telephone cord included with your new *CapTel* 800i phone.)
 2. Plug the other end of the telephone cord into a telephone wall outlet.
- You should have a dial tone to indicate the telephone service is connected properly.
 - Pick up the *CapTel* handset and listen for a dial tone. The Signal Meter in the lower right corner of the display screen shows when a dial tone is present (see page 24).

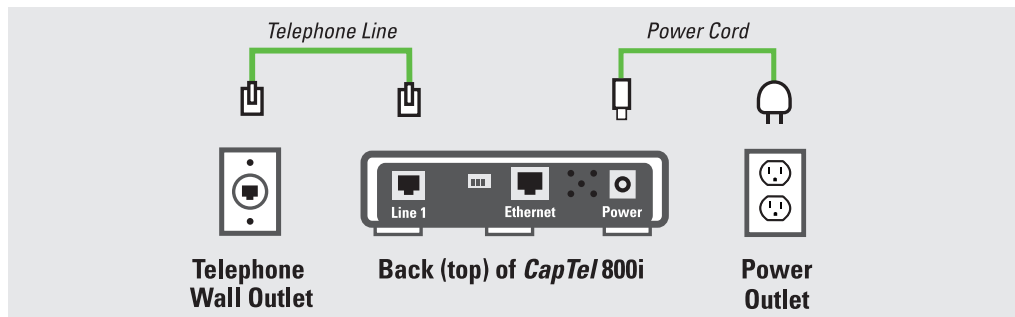

Connect to your Internet service

1. Plug one end of the Ethernet cable into the Ethernet jack labeled “Ethernet” located on the back (top) edge of the *CapTel* 800i.
(Use the Ethernet cable included with your new *CapTel* 800i phone.)
2. Connect the other end of the Ethernet cable into the jack you use for accessing your Internet service. Depending on how your Internet service is set up for your home/office, you could be plugging the Ethernet cable into any of the following:
 - An available Ethernet jack on a router in your home
 - An available Ethernet jack on a Digital Cable modem
 - An available Ethernet jack on a DSL modem
 - An available Ethernet wall jack

Example 1

All connection outlets (telephone, Ethernet, power) are available in the same room that you are planning to use the *CapTel* 800i.

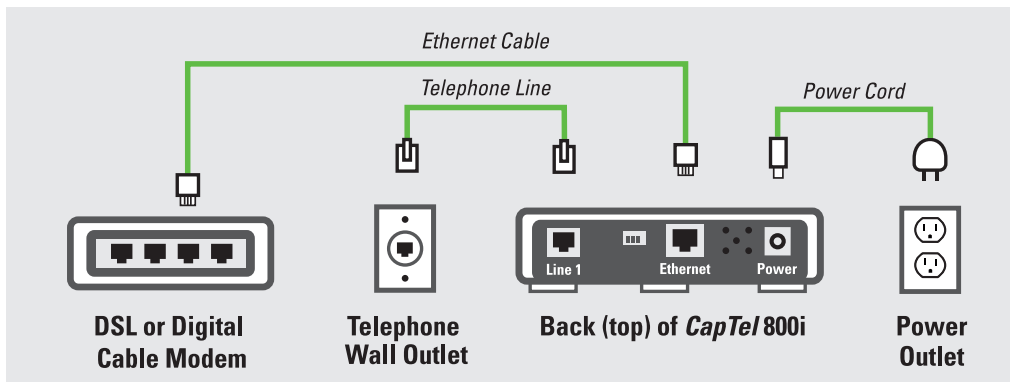

Example 2

If there are no available Ethernet jacks in your DSL or Cable Modem, you will need a Router that lets you connect more than one device to the Internet. Connect the Router to your DSL or Cable Modem. Then connect the *CapTel* 800i to the Router (using the Ethernet cable).

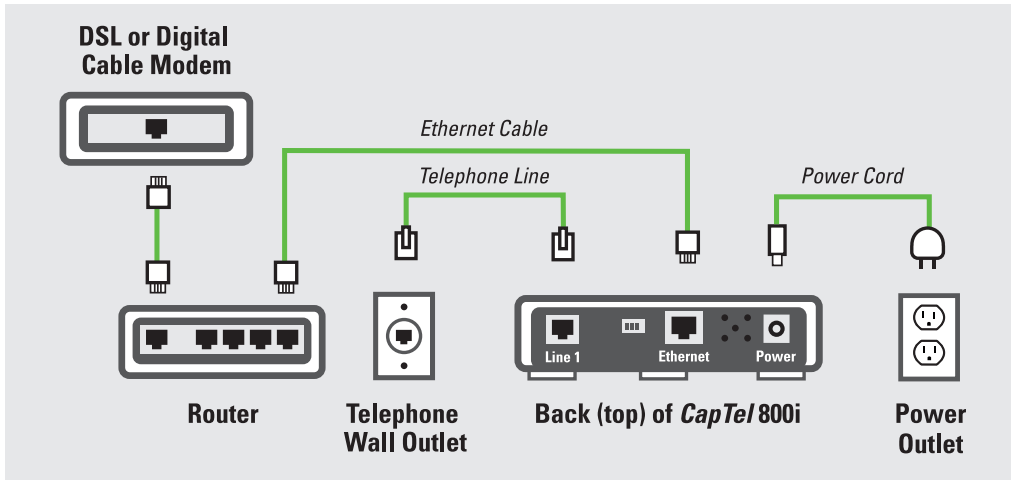

NOTE: When connected properly, the orange LNK indicator light will glow. The LNK indicator light is located next to the Ethernet jack on the back (top) edge of the CapTel 800i. The green ACT indicator light may occasionally blink, or it may stay dark.

For complete set up instructions, please see the Installation Guide.

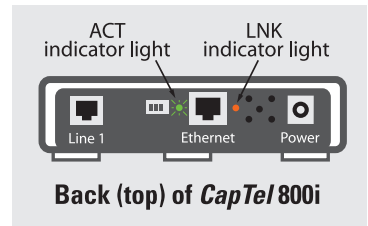

Getting Help

If you have any questions, comments, or concerns as you use your new *CapTel* 800i, we're here to help. Use any of these ways to contact us:

CUST
SERV



CUST SERV Button

Pick up the handset and press the **CUST SERV** button to automatically speed dial directly to our helpful Customer Service team. If you are in an office setting, you may need to dial “9” first and then press the **CUST SERV** button.

On-demand help is available Monday-Friday during standard business hours.



Phone: 1-888-269-7477

FAX: (608) 204-6167



Mail: CapTel Customer Service
450 Science Drive
Madison, WI 53711



Email: CapTel@CapTel.com

Online: www.CapTel.com

Making and Answering Calls

This section explains how to place outgoing calls and how to answer incoming calls with your CapTel 800i.

TOPICS:

- **Dialing a Phone Number Directly**
- **Calling Using the Speed Dial Buttons**
- **Calling a Number in the Phone Book**
- **Answering an Incoming Call**
- **Turning Captions On/Off During a Call**
- **Adjusting the Volume**
- **Adjusting the Sound – TONE**
- **Knowing What Sounds are on the Line**

Dialing a Phone Number Directly

CAPTIONS



Before you dial, check whether the **CAPTIONS** button is on (red light on). You can turn captions on/off at any time during your call by pressing the **CAPTIONS** button.

1. Lift the handset.
2. Dial the phone number of the person you wish to call.
3. As you dial, the display screen shows the status as your *CapTel* phone connects to the captioning service, letting you know when captions are ready.
4. Listen or watch the signal meter to know when someone answers. Watch the display screen for captions. Begin your conversation as you normally would.

When you are done with your call, hang up the handset.

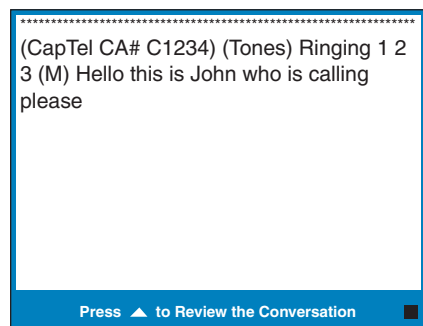
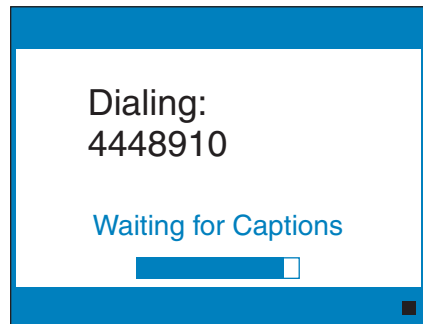
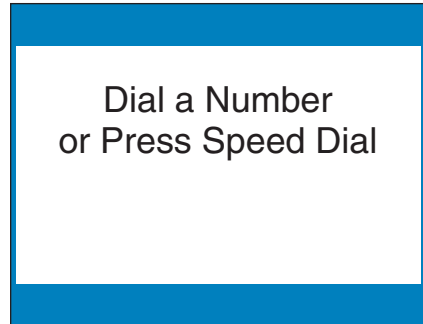

TIP: Remember to dial 1+ area code if the number you are calling is long distance.

TIP: You may want to let the person you are calling know you are using a Captioned Telephone, or you may choose not to mention it. The choice is yours.

Calling Using the Speed Dial Buttons

NOTE: You must save telephone numbers in the Speed Dial buttons before they can be used to dial. Please see page 49 for directions.

CAPTIONS



1. Make sure that the **CAPTIONS** button is on (red light on).

SPEED
DIAL



2. Press the **SPEED DIAL** button with the number that you want to call.

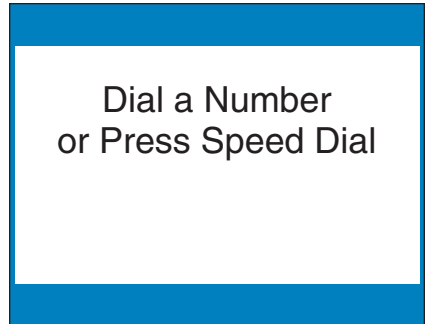

3. Lift the handset. Your *CapTel* phone will dial the phone number for you automatically. As you dial, the display screen shows the status as your *CapTel* phone connects to the captioning service, letting you know when captions are ready.

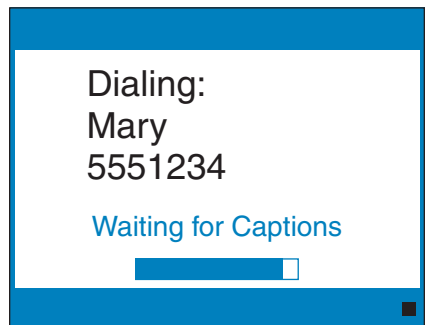

4. Listen or watch the signal meter to know when someone answers. Watch the display screen for captions. Begin your conversation as you normally would.

When you are done with your call, hang up the handset.

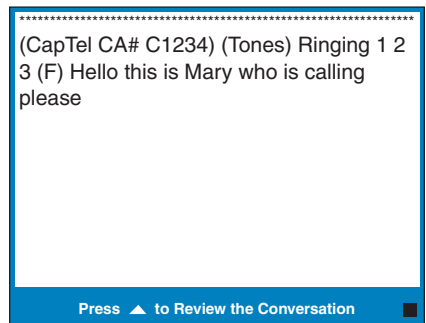

Calling a Number in the Phone Book

NOTE: Phone numbers must already be saved in the Phone Book before you can use the Phone Book to dial. Please see page 42 for directions.

CAPTIONS



1. Make sure that the **CAPTIONS** button is on (red light on).



2. With the handset hung up, press the **YES** button to see Options.



3. Press **DOWN** arrow to select **Dial from Phone Book**. Press the **YES** button to select.



4. Press the **UP** arrow or **DOWN** arrow buttons to find the person you want to call.



5. Pick up the handset. Your *CapTel* phone dials the number for you automatically.

6. Listen or watch the signal meter to know when someone answers. Watch the display screen for captions. Begin your conversation as you normally would.

When you are done with your call, hang up the handset.

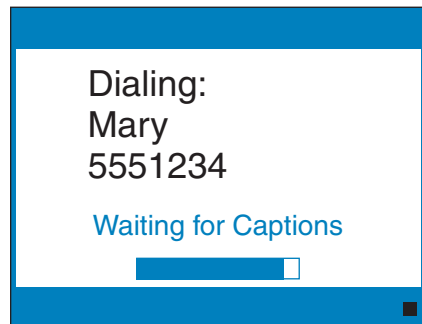
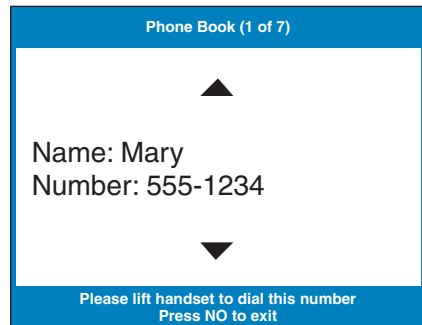
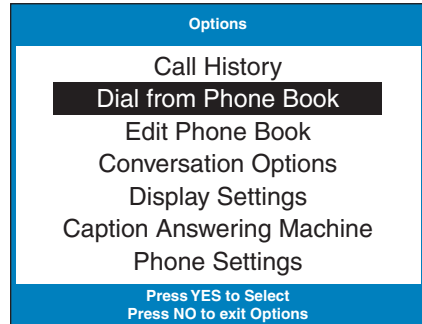

Answering an Incoming Call

1. When your *CapTel* phone rings, the display will light up to alert you to an incoming call.

NOTE: *If you have Caller ID service, you will see the name and/or the phone number of the person calling.*

2. Pick up the handset, and answer the call as you normally would.

CAPTIONS



3. Check to make sure the **CAPTIONS** button is on (red light on) if you'd like captions during the call. Press the **CAPTIONS** button to turn it on or off.

4. Listen or watch the signal meter for a response. Watch the display screen for captions.

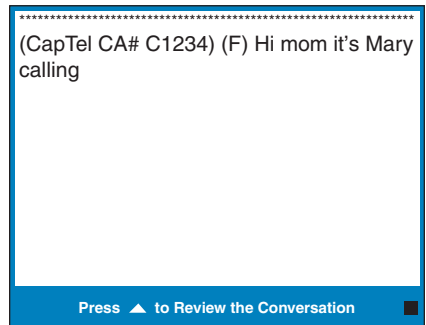
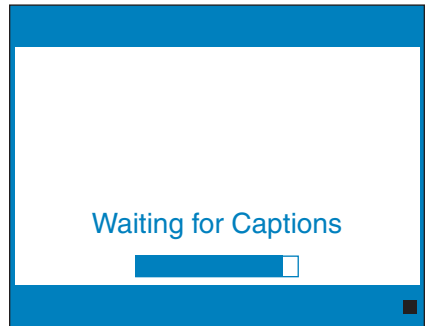
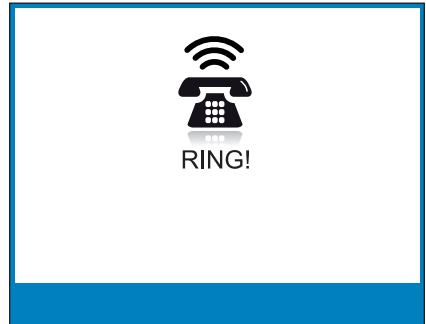

TIP: *If you answer on an extension telephone and want to get captions, just pick up the CapTel handset and press any of the number keys. Your CapTel phone will connect to the Captioning Service, and you will be able to view captions of the call on the CapTel display screen.*

Turning Captions On/Off During a Call

CAPTIONS You can turn captions on/off at any time during your call by pressing the **CAPTIONS** button. When the red light around the **CAPTIONS** button is lit, you will see captions of everything the other party says.



CAPTIONS To turn captions off, press the **CAPTIONS** button again. The red light around the **CAPTIONS** button will go off.



Adjusting the Volume

You can increase the volume of the person's voice coming through the handset, up to a 40 dB gain from min/max on captioned calls. Watch the lights above the VOLUME bar to see what level the volume is set to.



To increase the volume (make sounds louder) during a call, press the ▲ right side of the VOLUME bar.

To decrease the volume (make sounds softer) during a call, press the ▼ left side of the VOLUME bar.

WARNING: *The maximum volume setting on captioned calls is extremely loud. People who do not need amplification should not use the phone at its highest volume setting. The volume level automatically returns to a mid-range setting whenever the phone is hung up.*

Adjusting the Sound – TONE

You can adjust the Tone setting to a frequency range that works best for your hearing level – to emphasize HIGH, MEDIUM, or LOW frequency sounds. The Tone setting can be adjusted during, before, or after a call. The setting will remain in effect until you change it again.

TONE  If you hear low-frequency tones better, press the **TONE** button repeatedly until you see “Tone is Low” on the display screen.

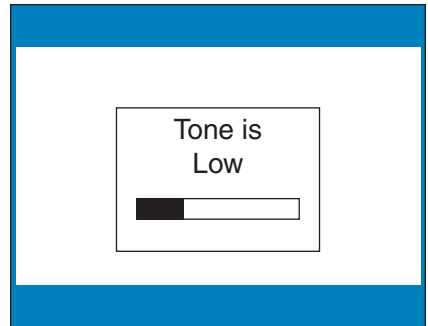

TONE  If you hear mid-range frequencies best, press the **TONE** button repeatedly until you see “Tone is Medium” on the display screen.

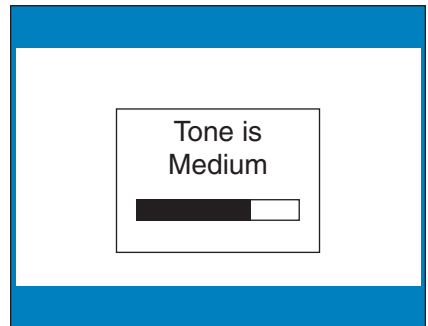

TONE  If you hear high-frequency tones better, press the **TONE** button repeatedly until you see “Tone is High” on the display screen.

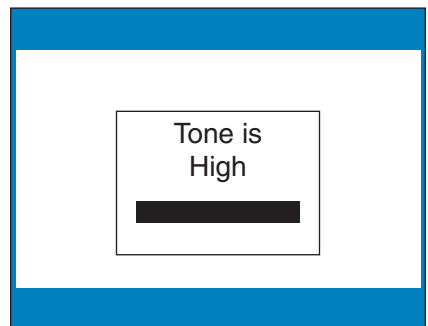

NOTE: *You can also use a headset or neckloop to enhance the sound quality. Please see page 11 for instructions.*

Knowing What Sounds Are on the Line

The display screen tells you what sounds are occurring during your call with two visual indicators: the Signal meter and the Outgoing Volume meter. These meters only appear during captioned calls.

The Signal Meter

This helpful meter lights up to indicate sounds on the handset, such as the caller's voice or a busy signal. It shows whenever a sound is coming through the handset, even if the sound is not loud enough for you to hear. The size of this meter expands and contracts with the volume of the sound. Very loud sounds cause the meter to completely light up the whole box. Quiet sounds may cause just a single dot on the display to light up. This meter can help you gauge when a person is finished speaking or initially answers a call.

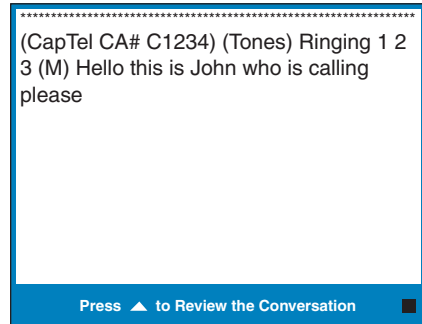

↑
**Signal
Meter**

The Outgoing Volume Meter

This meter helps you see how loudly you are speaking. More of the bar lights up if you speak loudly. Less of the bar lights up if you speak quietly. You can use the volume meter to gauge the volume of your own voice during a call.

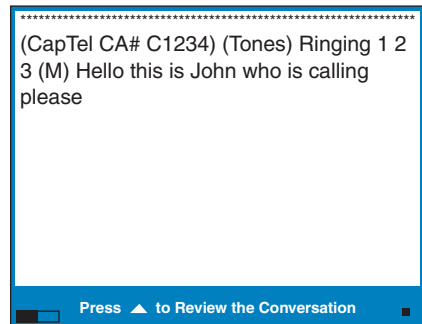

↑
**Outgoing
Volume
Meter**

NOTE: *If the Outgoing Volume Meter is filling completely or consistently turns red, you may be speaking too loudly.*

Viewing Captions

This section explains how to adjust and review conversation captions.

TOPICS:

- **Turning Captions On/Off During a Call**
- **Reviewing Captions During a Call**
- **Reviewing Captions After Hanging Up**
- **Saving Conversations**
- **Deleting All Conversations**
- **Changing the Caption Font Size**
- **Setting the Color of the Captions**
- **Adjusting the Brightness of the Display Screen**

Turning Captions On/Off During a Call

CAPTIONS



You can turn captions on/off at any time during your call by pressing the **CAPTIONS** button. When the red light around the **CAPTIONS** button is lit, you will see captions of everything the other party says. When the light is off, you will not receive captions.

CAPTIONS



If you turn captions on in the middle of a call, there will be a brief delay as your *CapTel* 800i phone connects to the Captioning Service. Then, captions will begin. During this time, you may still talk/listen to the other party. You do not need to wait for captions to begin if you can hear the other party well enough to carry on the conversation. You can speak at any time even if captions are present.

Reviewing Captions During a Call



While on a call, press the **UP** button to scroll back through captions that appeared earlier in the conversation. You can continue talking or listening while you review captions. Everything the other party says will continue to be captioned, even while you are looking back at earlier captions.

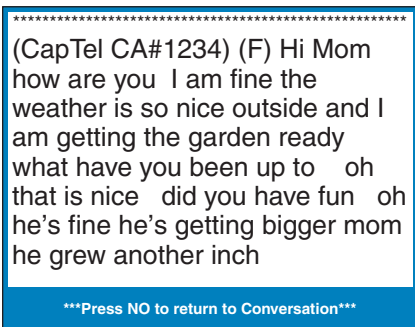

When you are ready to return to the live conversation captions, press the **NO** button. Anything the other party said during the time you were reviewing captions will appear, and the live captions will continue as usual.

You can go back, again, at any time during the call to review what was said. Just press the **UP** arrow button.

Reviewing Captions After Hanging Up

To review captions after your conversation is ended and the phone is hung up:



1. With the handset hung up, press the **YES** button to see Options.



2. Press the **DOWN** button repeatedly until **Conversation Options** is highlighted. Press the **YES** button to select.



3. Press the **YES** button to select **Review Conversations**. You will see captions of your conversations, with the most recent call on the bottom of the screen. Previous conversations may appear further up the display screen.



4. Press **UP** or **DOWN** button to scroll through the saved conversations.



5. When you are done, press **NO** to exit out of REVIEWING CAPTIONS.



6. Press the **NO** button repeatedly to exit out of the menu system.

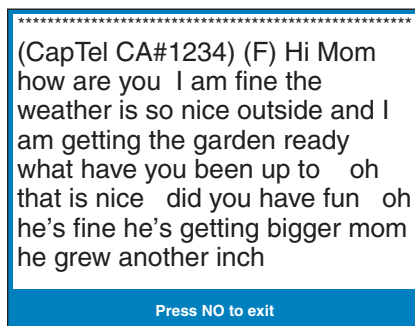
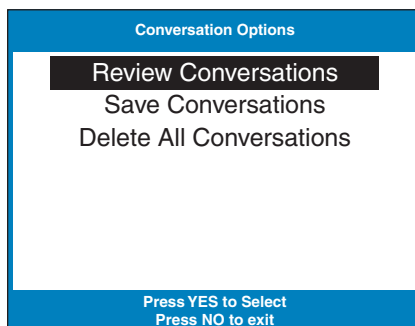
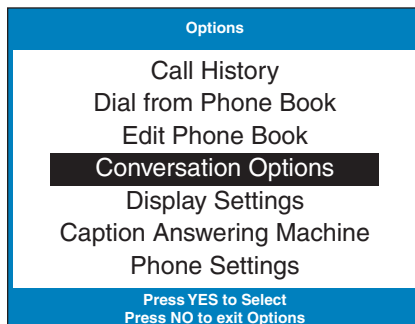

NOTE: Your CapTel phone comes with the Save Conversations feature enabled, letting you view conversation captions after you've hung up the phone. To turn off this feature, please see page 28. If you turn off the Save Conversations feature, all conversation captions will be erased every time you hang up the phone.

Saving Conversations

You can set your *CapTel* phone to Save Conversations after the call has ended and the phone is hung up. This allows you to go back and review what was said after you've hung up. You can review up to 480 lines of conversation captions. Or, you can have captions erased every time the phone is hung up. The default setting is to Save Conversations after the call is ended.

To change the Save Conversations setting:



1. With the handset hung up, press the **YES** button to see Options.



2. Press the **DOWN** button repeatedly until **Conversation Options** is highlighted. Press the **YES** button to select.



3. Press the **DOWN** button until **Save Conversations** is highlighted. Press the **YES** button to select.



4. Press **UP** or **DOWN** button to select **Enabled** or **Disabled**.

Enabled saves conversation captions after the call is finished and the phone is hung up.

Disabled erases the conversation captions after every call.

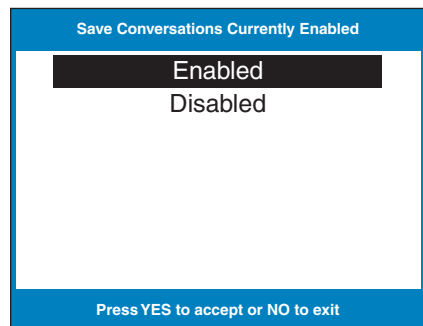
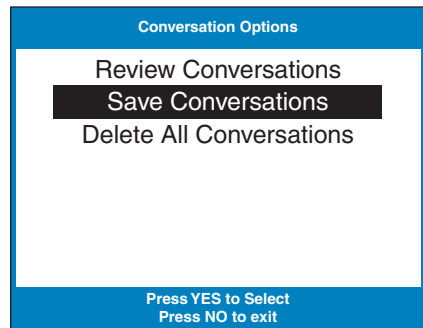
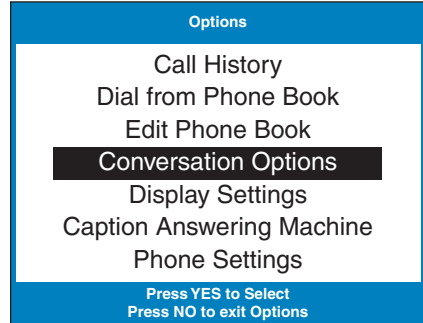



5. After you've made your selection, press the **YES** button to accept or the **NO** button to exit out of Conversation Options.



6. Press the **NO** button repeatedly to exit out of the menu system.

NOTE: *Setting will remain Enabled/Disabled until you change it again.*

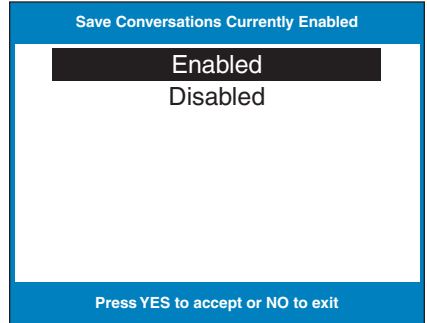

Deleting All Conversations

You can delete all conversation captions stored in memory. To delete your saved conversations:



1. With the handset hung up, press the **YES** button to see Options.



2. Press the **DOWN** button repeatedly until **Conversation Options** is highlighted. Press the **YES** button to accept.



3. Press the **DOWN** button until **Delete All Conversations** is highlighted. Press the **YES** button to accept.

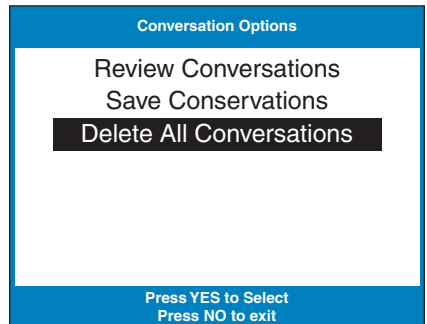
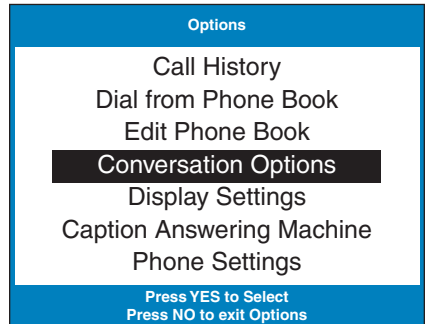



4. The display screen asks if you'd like to **Delete All Conversations?**



Press the **YES** button to delete captions. Or, press the **NO** button to exit.

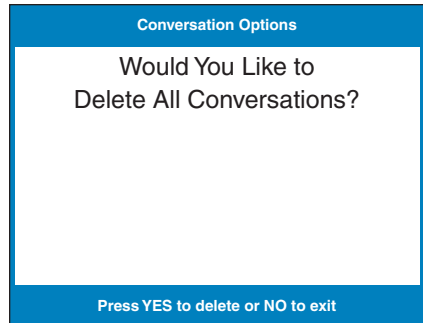

5. Press the **NO** button repeatedly to exit out of the menu system.

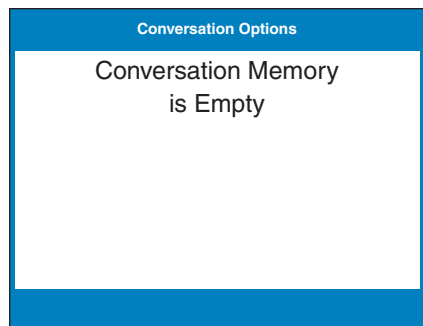

Changing the Caption Font Size

You can adjust the font size of the conversation captions to be larger or smaller, making the captions easier to read. You need to change the font size before or after a call, you cannot change the font size during a live captioned call.

NOTE: *Changing the font size applies only to conversation captions. The font size and style for your CapTel 800i menu Options always remains the same.*

To change the caption font size:



1. With the handset hung up, press the **YES** button to see Options.



2. Press the **DOWN** button repeatedly until **Display Settings** is highlighted. Press the **YES** button to select.



3. Press the **DOWN** button until **Set Conversation Font Size** is highlighted. Press the **YES** button to select.

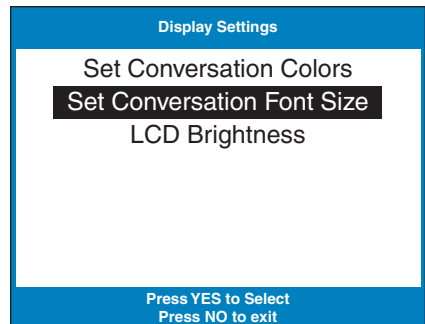
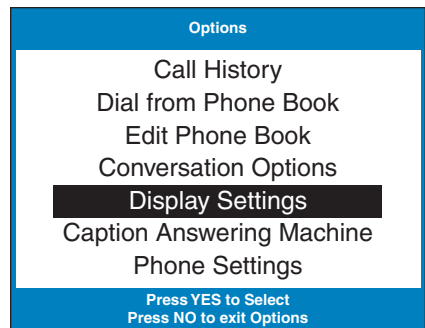

4. The display screen shows what the current font size setting is.



5. Press **UP** or **DOWN** buttons to select the font size you want: SMALL, MEDIUM, or LARGE.



6. Once you've selected the font size, press the **YES** button to accept or press the **NO** button to exit.



7. Press the **NO** button repeatedly to exit out of the menu system.



NOTE: *You need to adjust/select the caption font size before or after a call. You cannot adjust the caption font size during a live call.*

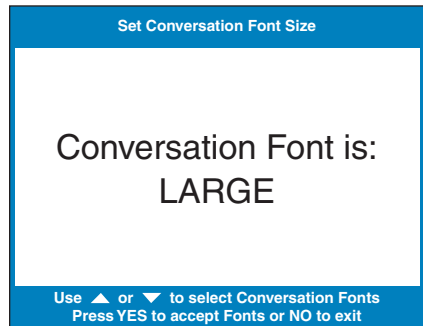
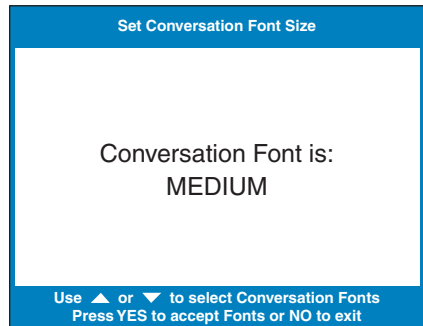
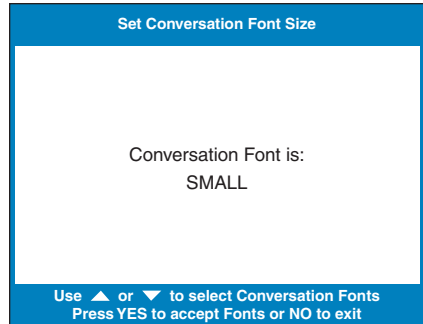

WARNING: *Changing the font size will delete all previously saved conversations.*

Setting the Color of the Captions

You can change the color of the caption font and the background color on the display screen to a color combination that you prefer. You need to set the conversation colors before or after a call. You cannot change the caption colors during a live captioned call. Color choices include: WHITE, RED, GREEN, BLUE, CYAN, MAGENTA, GRAY, BLACK OR YELLOW.

NOTE: *Changing the font/background color applies only to conversation captions. The font size and style for your CapTel 800i menu Options always remains the same.*

To change the caption font and background color:



1. With the handset hung up, press the **YES** button to see Options.



2. Press the **DOWN** button repeatedly until **Display Settings** is highlighted. Press the **YES** button to select.



3. Make sure that **Set Conversation Colors** is highlighted. Press the **YES** button to select.

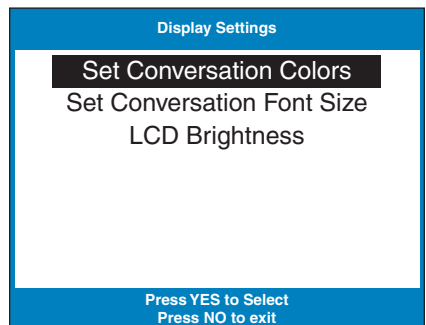
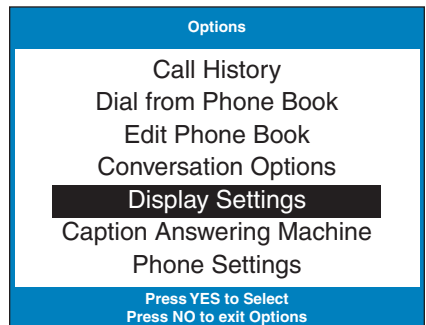



- The display screen shows what the current text color and background color are set to, with an ▶ pointing toward the **Text Color** setting. Press the **YES** button to select **Text Color**.

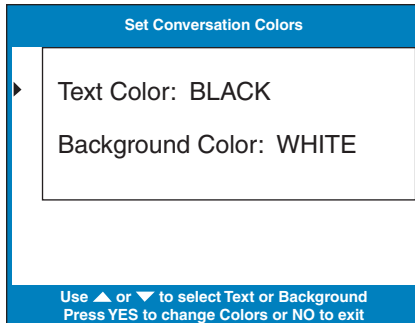

- A color palette appears on the bottom of the display. Use the **UP** and **DOWN** arrow keys to move through the various font color choices. When you find a font color you prefer, press the **YES** button to accept.



- The display ▶ moves down to indicate **Background Color**. Press the **UP** and **DOWN** arrow keys to move through the various background color choices. When you find a background color you prefer, press the **YES** button to accept.



- Press the **NO** button repeatedly to exit out of the menu system.

NOTE: *Whichever color you select for text will not be available as a background color choice. If you want to reverse the font and background colors, you may need to set a temporary color choice for the font first, before setting the background color. Then you can come back and re-adjust the font color separately.*

Adjusting the Brightness of the Display Screen

You can adjust the brightness of your *CapTel* 800i display screen to make it easier to read in well-lit or dimly lit environments.

NOTE: *You need to adjust the brightness of the Display Screen before or after a call. You cannot set the display screen brightness during a live captioned call.*

To adjust the brightness of the Display Screen:



1. With the handset hung up, press the **YES** button to see Options.



2. Press the **DOWN** button repeatedly until **Display Settings** is highlighted. Press the **YES** button to select.



3. Press the **DOWN** button repeatedly until **LCD Brightness** is highlighted. Press the **YES** button to select.

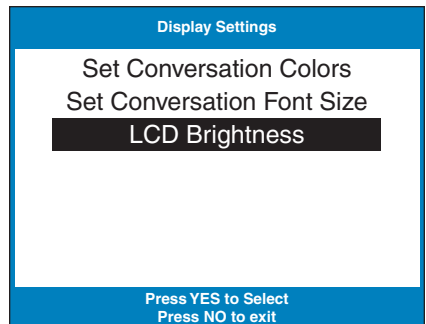
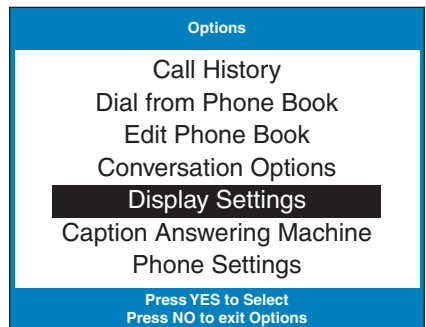



4. The display screen shows what the current brightness level is set to: Minimum, Medium, or Maximum. Use the **UP** and **DOWN** arrows to highlight the level of brightness you would like. Press the **YES** button to select.



NOTE: *The display screen will change brightness levels as you select the options.*



5. Press the **NO** button repeatedly to exit out of the Options menu.

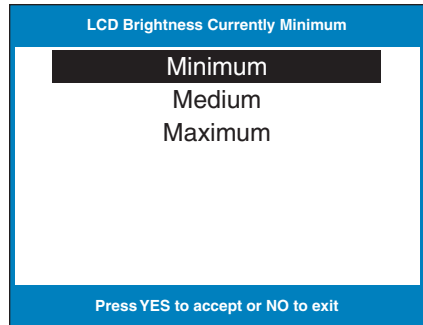

Call History

This section explains how to use Call History to see who has called you and to see any incoming calls that you may have missed.

TOPICS:

- **Using Call History to See Recent Calls**
- **Clearing All Caller ID Entries**

NOTE: *Call History requires Caller ID service from your phone company. If your phone service does not include Caller ID, you will not be able to view Call History with your CapTel 800i.*

Using Call History to See Recent Calls

Your *CapTel* 800i phone keeps a list of the most recent incoming phone calls, including calls you may have missed.

The *CapTel* display screen automatically shows you the phone number of the person who called you most recently, even if you were not there to answer the call. Depending on your Caller ID service, the display screen may also list the name of the caller. To see other caller's information saved in **Call History**, press the DOWN button to scroll back through recently received calls.

Missed Calls

Any unanswered calls appear as New Calls in the display screen.



1. To review calls, press the **DOWN** arrow button.



2. Use the **UP** and **DOWN** arrow buttons to move backwards and forwards through previous call listings.

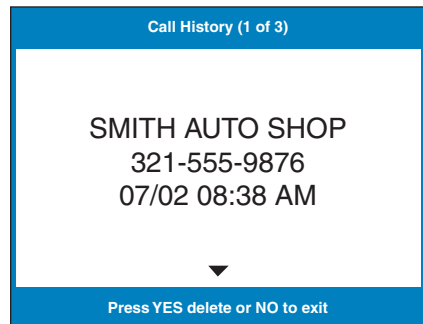
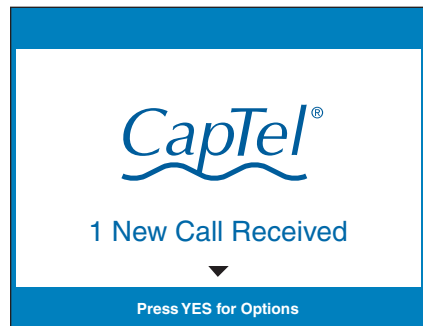

Previous Calls

You can review Call History information from previous calls at any time. To review recent calls in Call History:



1. With the handset hung up press the **YES** button to see Options.



2. Check that **Call History** is highlighted. Press the **YES** button to accept.

3. The *CapTel* display screen will show you a list of phone numbers of calls to your *CapTel* 800i, listing the most recent call first and going back in chronological order.



4. Use the UP and DOWN arrow buttons to move backward and forwards through previous call listings.

NOTE: *You can delete Caller ID entries as you review them by pressing the YES button.*



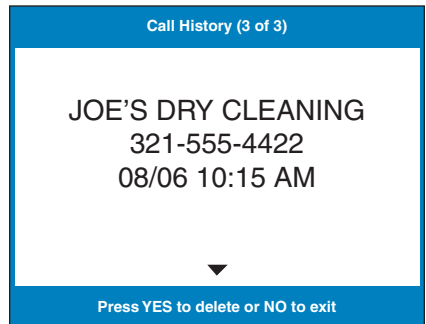
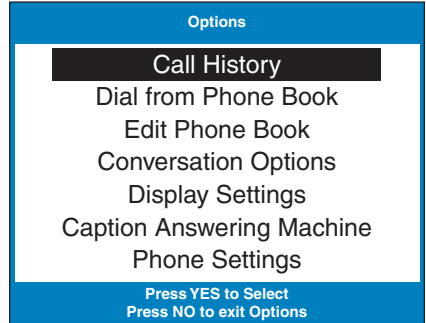

5. When you are done, press the **NO** button repeatedly to exit out of Call History.



Clearing All Caller ID Entries

You can delete individual Caller ID entries as you review them (see page 39) or you can erase all Caller ID records at one time.

To clear (delete) all Caller ID entries:

-  1. With the handset hung up, press the **YES** button to see Options.
-  2. Confirm that **Call History** is highlighted. Press the **YES** button to select.
-  3. Use the **DOWN** button to highlight **Clear All Caller ID Records**. Press the **YES** button to select.
4. The *CapTel* 800i will erase all Caller ID records.
5. Press the **NO** button repeatedly to exit out of the Options menu.

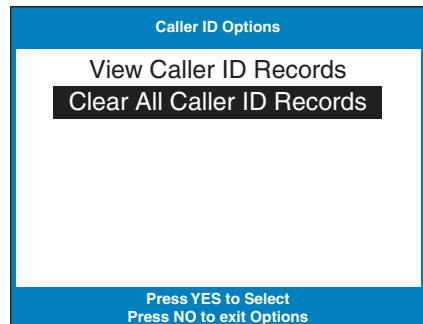
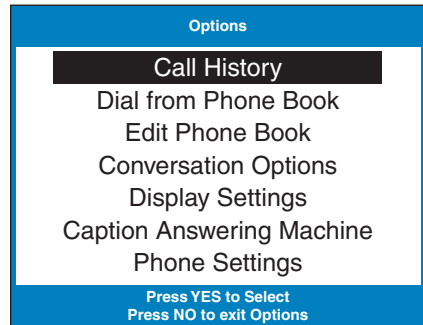

Using the Phone Book





This section explains how to save frequently-called phone numbers into your phone book for easy dialing.

TOPICS:

- **Adding a New Contact to your Phone Book**
- **Dialing a Phone Number from the Phone Book**
- **Editing an Existing Contact in the Phone Book**
- **Removing a Contact from your Phone Book**

Adding a New Contact to your Phone Book

You can save 97 names and phone numbers in the *CapTel* 800i Phone Book. To add a new contact to the Phone Book:

-  1. With the handset hung up, press the **YES** button to see Options.
-  2. Press the **DOWN** button repeatedly until **Edit Phone Book** is highlighted. Press the **YES** button to select.
- 
 3. Press the **DOWN** button until **Add a New Contact** is highlighted. Press the **YES** button to select.
-  4. Use the dialing pad to enter the letters of the name of the person you wish to add. Look for the letters listed on the number keys to know which number key to press. For some letters, press the number key several times until the correct letter appears on the display screen.

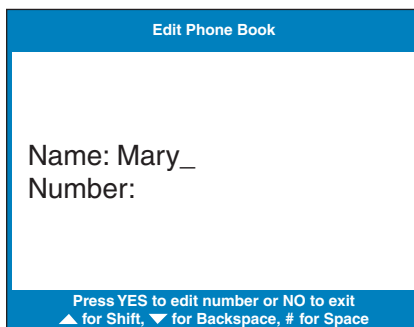
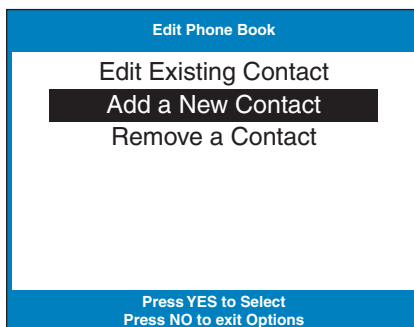
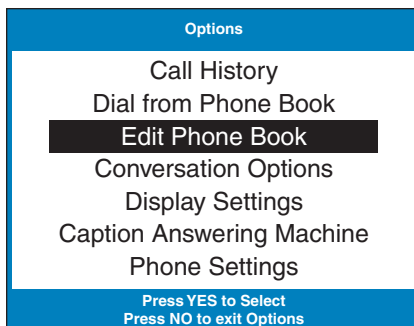

Example: To enter the letter “L”, press the number 5 key three times until you see “L” on the display screen.

Example: To enter the name “Mary”, press the 6 key for the letter “M”, the 2 key for the letter “a”, the 7 key three times for the letter “r”, then the 9 key three times for the letter “y”. You may need to wait for the cursor to change from | to _ when entering letters that are on the same number key.

TIP: Press the DOWN button for a backspace. Press the # button to add a space. Press the UP button to shift lock for capital letters. Press UP again to return to lower case.



5. Once you have entered the contact name, press the **YES** button to advance to the Number section.



6. Enter in the phone number by using the dialing pad. Use the **DOWN** button to backspace.

NOTE: If a dialing prefix is required to get an outside line, enter in the dialing prefix first, then the phone number. Use the **UP** button to add a 2-second delay.



7. When you are done entering the phone number, press the **YES** button to save your new contact information.



Press the **YES** button to enter more contact names/phone numbers, or press the **NO** button repeatedly to exit the menu system.



Edit Phone Book

Name: Mary
Number: _

Press YES to accept or NO to exit
▼ for Backspace, ▲ for 2 second delay

Name: Mary
Number: 555-1234_

** Saved **

Dialing a Phone Number from the Phone Book

To quickly dial any phone number listed in your Phone Book:



1. With the handset hung up, press the **YES** button to see Options.



2. Press the **DOWN** arrow button to highlight **Dial from Phone Book**. Press the **YES** button to select.

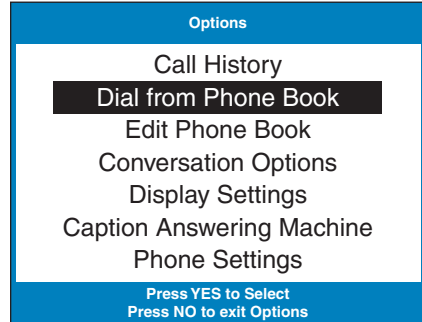

3. The display screen shows you the first contact name and number listed in your Phone Book. Use the **UP** and **DOWN** arrows to move through the contacts in your Phone Book.

4. When you see the contact listing you want to dial, simply lift the handset. The *CapTel* phone will dial the number for you automatically.

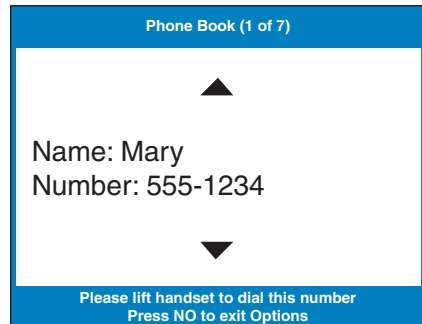

Editing an Existing Contact in the Phone Book

To make changes to an existing contact in the Phone Book:



1. With the handset down, press the **YES** button to see Options.



2. Press the **DOWN** button repeatedly until **Edit Phone Book** is highlighted. Press the **YES** button to accept.



3. Check that **Edit Existing Contact** is highlighted.



4. Press the **YES** button to select.



5. The display screen will show you the first listing in your Phone Book. Use the **UP** and **DOWN** arrow buttons to move through the various contacts in your Phone Book. When you find the contact you wish to change, press the **YES** button to select it.

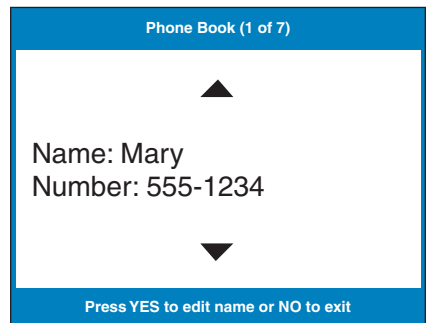
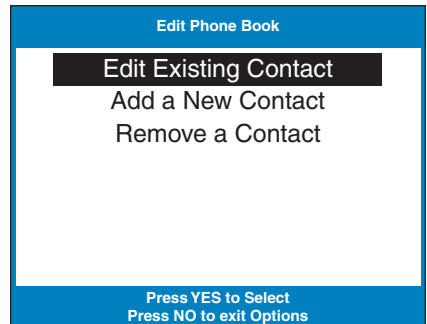
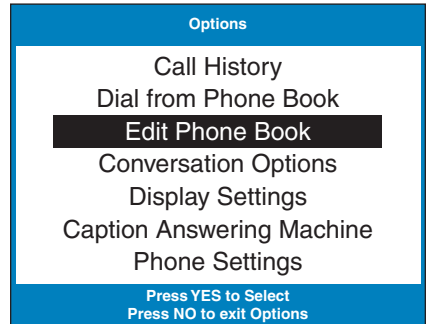



6. To edit the name, use the **DOWN** arrow button as a backspace to erase letters. You can enter new/different letters using the dialing pad. Look for the letters listed on the number keys to know which number key to press. For some letters, press the same number key several times until the correct letter appears on the display screen.

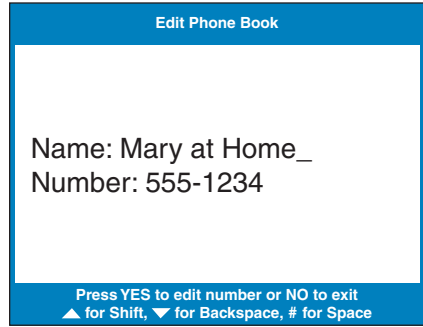

7. When you are done editing the name, press the **YES** button to move to the Number.



To edit the phone number, use the **DOWN** arrow button as a backspace to erase numbers. You can enter new/different numbers using the dialing pad. Use the **UP** arrow button to insert a 2-second delay.

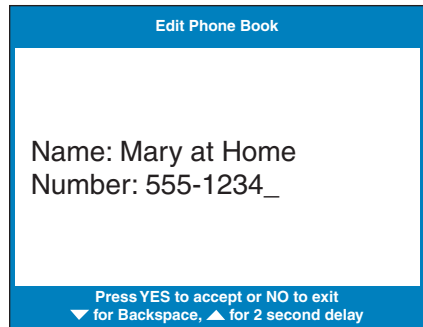

NOTE: *If a dialing prefix is required to get an outside line, enter in the dialing prefix first, then the phone number.*



8. When you are done editing the phone number, press the **YES** button to save your changes.

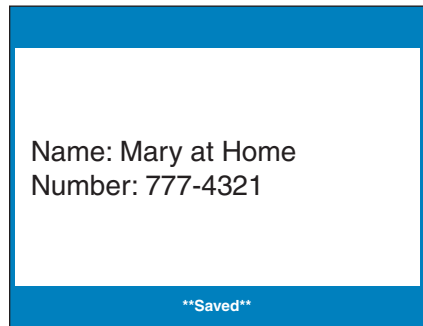

9. Press the **YES** button to edit more contacts in your Phone Book, or press the **NO** button repeatedly to exit the menu system.



Removing a Contact from your Phone Book

To remove a contact from your Phone Book:



1. With the handset down, press the **YES** button to see Options.



2. Press the **DOWN** button repeatedly until **Edit Phone Book** is highlighted. Press the **YES** button to select.



3. Press the **DOWN** button repeatedly until **Remove a Contact** is highlighted. Press the **YES** button to select.



4. The display screen will show you the first listing in your Phone Book. Use the **UP** and **DOWN** arrow buttons to move through the various contacts in your Phone Book until you see the contact listing you wish to delete.



5. Press the **YES** button to remove the contact listing. The name and phone number of the contact person will be deleted from the Phone Book.



6. Press the **NO** button repeatedly to exit out of the Options list.

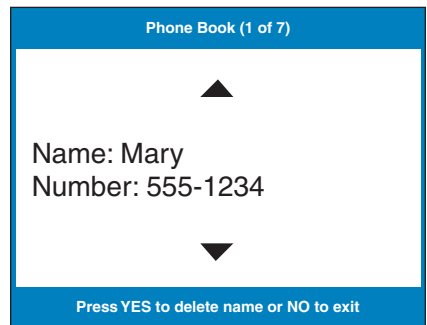
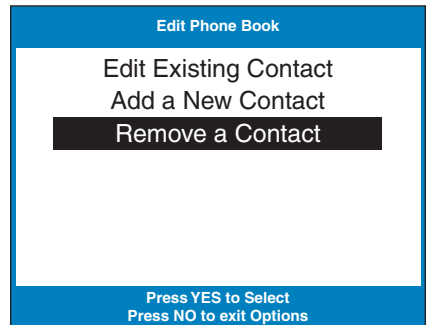
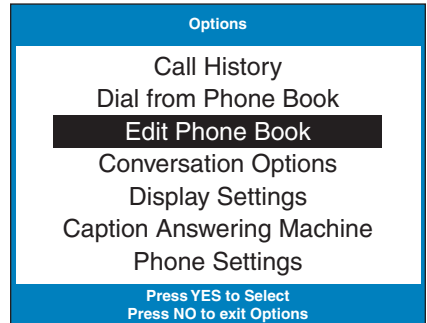

Using Speed Dial Buttons

This section tells you how to set up and use the three Speed Dial buttons on your CapTel phone.

TOPICS:

- **About the Speed Dial Buttons**
- **Saving Phone Numbers in the Speed Dial Buttons**
- **Editing Phone Numbers in the Speed Dial Buttons**
- **Dialing with the Speed Dial Buttons**

About the Speed Dial Buttons

You can set up three speed dial buttons on your *CapTel* phone to easily dial your most frequently-called phone numbers. You may want to use these buttons for emergency speed dial buttons to call the fire department or police, or to quickly reach a number you call often.

Saving Phone Numbers in the Speed Dial Buttons

SPEED
DIAL

1

1. With the handset hung up, press the **SPEED DIAL** button you want to program.



2. Press the **YES** button to edit.

3. Use the dialing pad to enter the letters of the name of the person you wish to add. Use the letters on the number keys to know which key to press.

Example: To enter the name “Mary”, press the 6 key for the letter “M”, the 2 key for the letter “a”, the 7 key three times for the letter “r”, then the 9 key three times for the letter “y”. You may need to wait for the cursor to change from | to _ when entering letters that are on the same number key.



4. Press the **YES** button to advance the selection to the Number section.

5. Enter in the phone number by using the dialing pad. (*Note: If a dialing prefix is required to get an outside line, enter in the dialing prefix then the numbers.*) Use the **DOWN** button to backspace. Use the **UP** arrow button to insert a 2-second delay.



6. Press the **YES** button to save it.

Speed Dial 1

Name: _____
Number: _____

Press YES to edit or NO to exit

Edit Speed Dial

Name: _
Number: _____

Press YES to edit number or NO to exit
▲ for Shift, ▼ for Backspace, # for Space

Edit Speed Dial

Name: Mary
Number: _____

Press YES to accept or NO to exit
▼ for Backspace, ▲ for 2 second delay

Editing Phone Numbers in the Speed Dial Buttons

SPEED
DIAL

1

1. Press the **SPEED DIAL** button you wish to edit.

YES

2. Press the **YES** button to edit the name.

DOWN

3. Use the **DOWN** arrow button to backspace/erase letters in the current name. Use the number pad keys to enter a new letter or name. Press the **YES** button when you are done editing the name.

YES

DOWN

4. The cursor moves to the Number entry. Use the **DOWN** arrow button to backspace/erase numbers in the current listing. Use the number pad key to change/enter a new phone number. Use the **UP** arrow button to insert a 2-second delay.

YES

5. When you are finished making changes, press the **YES** button to accept.

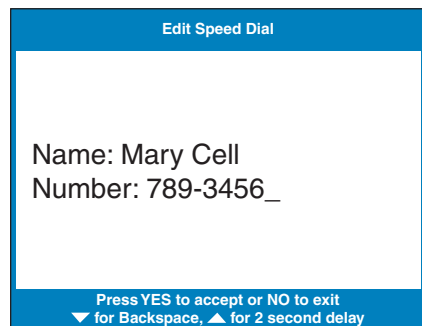
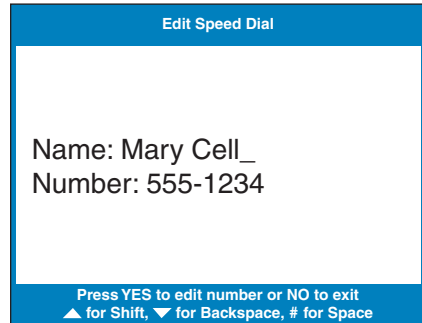
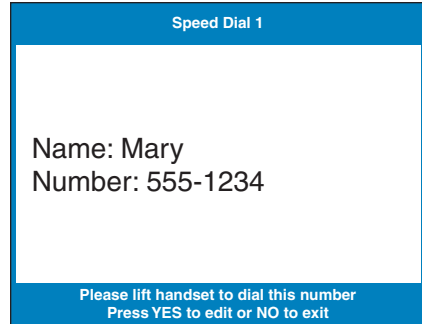

Dialing with the Speed Dial Buttons

CAPTIONS



1. Make sure that the **CAPTIONS** button is on (red light on).

SPEED
DIAL



2. Press the **SPEED DIAL** key with the number that you want to call.
3. Lift the handset. Your *CapTel* phone will dial the phone number for you automatically.

4. Listen or watch the signal meter to know when someone answers. Watch the display screen for captions. Begin your conversation as you normally would.

When you are done with your call, hang up the handset.

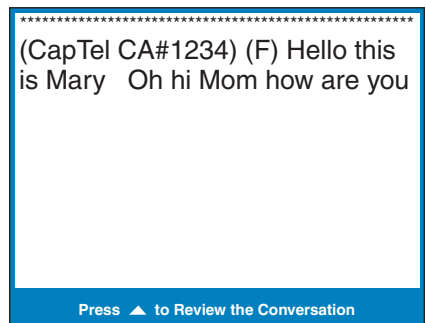
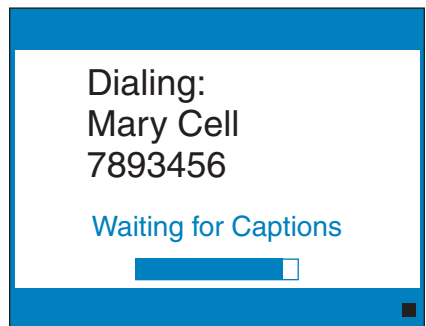
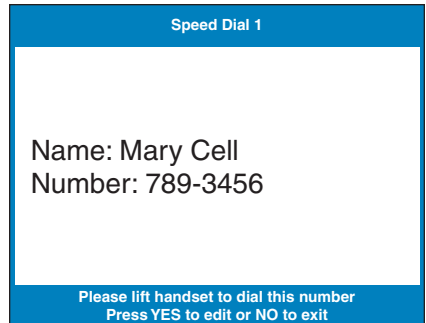

Seeing Captions of Your Answering Machine and Voice Mail Messages

This section explains how to see captions of voice mail messages or messages that people leave on your external answering machine.

TOPICS:

- **Seeing Captions of Your Answering Machine Messages**
- **Connecting an External Answering Machine**
- **Seeing Captions of Your Voice Mail Messages**

Seeing Captions of Your Answering Machine Messages

Your *CapTel* 800i can show captions of messages that people leave on your external voice answering machine.

NOTE: *CapTel* 800i does not have a built-in answering machine. The phone does not record messages for you when you are away. For directions on how to connect your *CapTel* 800i to an external answering machine, see page 54.

To get captions of your external answering machine messages:



1. With the handset hung up, press the **YES** button to see Options.



2. Press the **DOWN** button repeatedly until **Caption Answering Machine** is highlighted.



3. Press the **YES** button to select **Caption Answering Machine**.



4. The display screen shows that your *CapTel* is ready to caption messages. Press the **YES** button to accept.

5. Lift the *CapTel* 800i handset, and place it next to your answering machine speaker. Make sure the mouth-piece of the handset is next to the speaker on your answering machine. While you do this, your *CapTel* 800i connects to the captioning service.

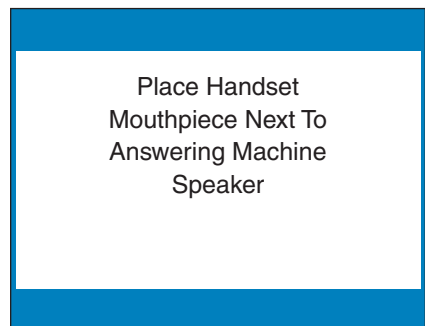
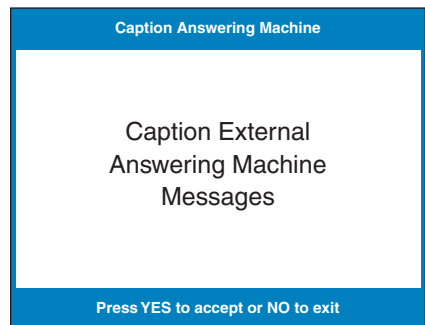
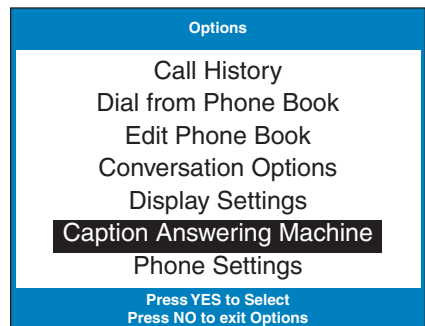

6. Once you see **Ready to Caption** the captioning service is connected. Press the “PLAY” button on your answering machine to play the messages aloud.

Your *CapTel* 800i will show you captions of the answering machine messages as they are played. During this time, you may operate your answering machine the way you normally would use your answering machine features (playing, re-playing, deleting, or saving messages).

When you are done listening to your messages/reading captions, hang up the *CapTel* 800i handset.

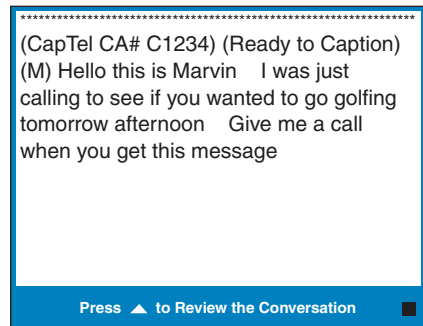
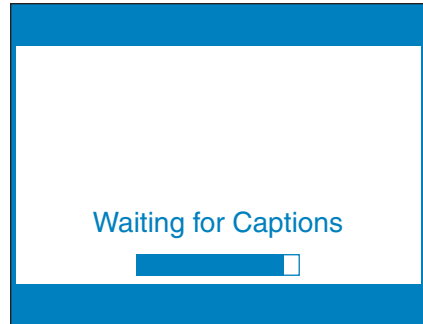

Connecting an External Answering Machine

Your new phone does not include a built-in answering machine, but you can connect the *CapTel* 800i to an external telephone answering machine (purchased separately).

Follow the instructions that came with your answering machine to connect the *CapTel* 800i phone in the same way you'd hook any other phone to the answering machine. You will still need to connect the *CapTel* 800i to your Internet service and to an electrical power wall outlet, as described in the *CapTel* 800i Installation Guide.

Seeing Captions of Your Voice Mail Messages

Some voice mail services require that you dial a remote access phone number or extension to access your voice mail messages. You can access your voice mail messages the same way using your *CapTel* 800i, plus you can see captions of your voice mail. The way that you access voice mail messages depends on what kind of service you use, but you should be able to access your messages using the *CapTel* 800i the same way you would with any telephone.

To get captions on voice mail messages:

CAPTIONS



1. Check that the **CAPTIONS** button is on (red light lit).
2. Lift the handset, and dial the telephone number or extension number that you use to access your voice mail messages.
3. Listen and read captions to follow the instructions to access your voice mail messages. As the messages are played, you can read captions in your *CapTel* display screen.

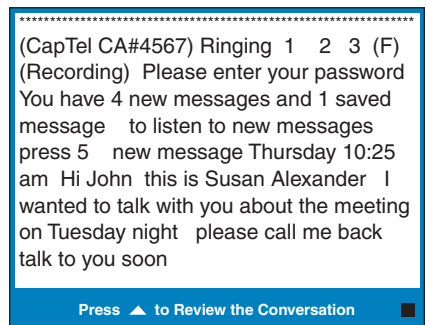
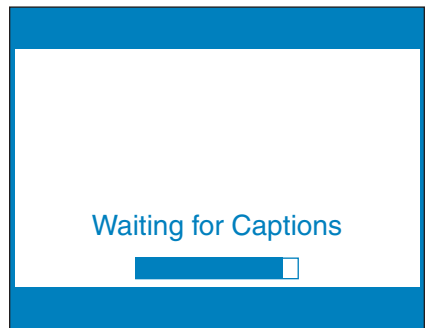

TIP: As you review voice mail messages, use the CapTel 800i to follow any instructions from your voice mail system, such as “Press 1 to re-play messages” or “Press 2 to delete”. You do not need to wait for the captions to make these key presses. Your CapTel 800i will continue to display captions of everything said over the phone.

CUST
SERV



If you have any questions or difficulty using your CapTel to access voice mail, CapTel Customer Service would be happy to assist you. Press the CUST SERV button or dial 1-888-269-7477 for help.

NOTE: If calling from an office, you may need to dial 9 first, then press the Customer Service button.

Telephone Settings

This section explains how to adjust settings on your phone to fit your preferences.

TOPICS:

- **Setting the Captions Default to On/Off**
- **Adjusting the Volume of the Ringer**
- **Setting the Pitch of the Ringer**
- **Turning the Ringer On/Off**
- **Setting your *CapTel* Phone for Tone/Pulse Dialing**
- **Turning on Spanish Captions**
- **Turning Keypad Lights On/Off**
- **Using Call Waiting**
- **Dialing 911 with Your *CapTel* 800i**
- **Updating your *CapTel* Phone**

Setting the Captions Default to On/Off

You can change the default setting of your *CapTel* 800i to always have the captions button set to ON or to always have the captions button set to OFF. Your *CapTel* 800i comes with the Captions Default set to ON.

NOTE: *No matter how you set the Captions Default, you can always turn the captions ON or OFF by pressing the Captions button at any point in the conversation.*

CAPTIONS

Captions Default On



When the caption default is set to ON, every call (incoming or outgoing) is automatically connected to the Captioning Service. The light around the **CAPTIONS** button remains lit. You will receive captions on every call. You can still turn the captions off by pressing the **CAPTIONS** button at any time during the call.

CAPTIONS

Captions Default Off



When the caption default is set to OFF, calls are not automatically connected to the Captioning Service. The light around the **CAPTIONS** button stays off. Calls are treated exactly like any regular telephone call, with you and the other party talking over the telephone line and no captions involved. Even with the captions default set to off, you can turn captions on by pressing the **CAPTIONS** button at any time during the call.

NOTE: *When the **CAPTIONS** button is off (red light is off) the maximum amplification level is not available.*

To change the Captions Default setting:



1. With the handset hung up, press the **YES** button to see Options.



2. Press the **DOWN** button repeatedly to highlight **Phone Settings**.



3. Press the **YES** button to select.



4. Check that **Caption Default On/Off** is highlighted. Press the **YES** button to select.



5. Press the **UP** or **DOWN** button to select **Captions Default On** or **Captions Default Off**.



6. Press the **YES** button to accept.



7. Press the **NO** button repeatedly to exit out of the Options menu.

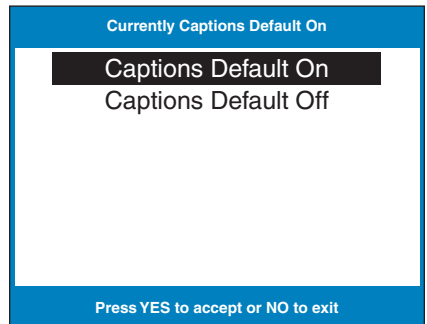
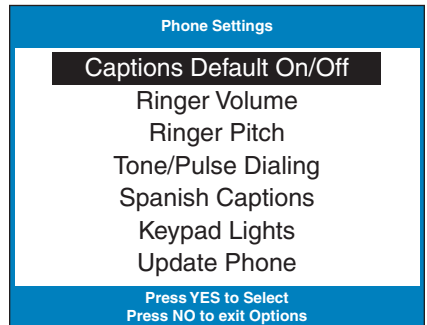
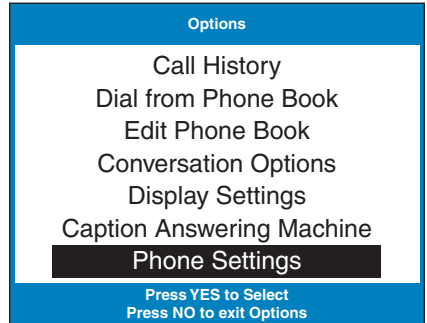

Adjusting the Volume of the Ringer

You can set the volume of the *CapTel* 800i ringer to the volume that you hear best: Choose from minimum volume (105 dB), medium volume (111 dB) or maximum volume (117 dB).

To set the Ringer volume:

-  1. Press the **YES** button to see Options.
-  2. Press the **DOWN** button until **Phone Settings** is highlighted.
-  3. Press the **YES** button to select.
-  4. Press the **DOWN** button until **Ringer Volume** is highlighted.
-  5. Press the **YES** button to select.
-  6. Press the **UP** or **DOWN** button to select your desired Ringer Volume level.
-  7. When the volume setting you want is highlighted, press the **YES** button to accept.
-  8. Press the **NO** button repeatedly to exit out of the Options menu.

NOTE: *If the Ringer switch is set to OFF, you will not be able to adjust the Ringer volume.*

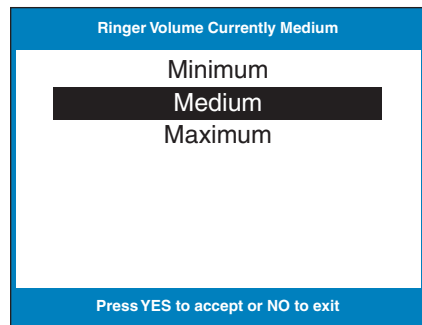
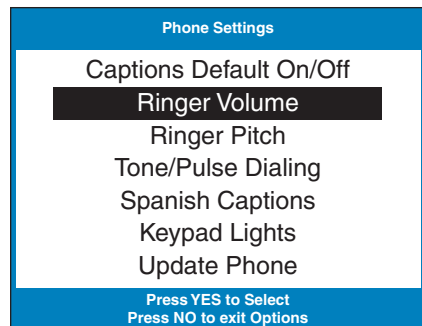
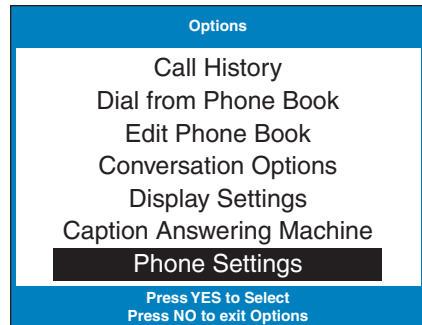

Setting the Pitch of the Ringer

You can select the Ringer pitch that helps you hear best, selecting from low, medium, or maximum.

To set the Ringer pitch:

-  1. Press the **YES** button to see Options.
-  2. Press the **DOWN** button until **Phone Settings** is highlighted.
-  3. Press the **YES** button to select.
-  4. Press the **DOWN** button until **Ringer Pitch** is highlighted.
-  5. Press the **YES** button to select.
-  6. Press the **UP** or **DOWN** button to select your desired Ringer Pitch level. The ringer will ring briefly as you switch levels.
-  7. When the **Ringer Pitch** level that you want is highlighted, press the **YES** button to accept.
-  8. Press the **NO** button repeatedly to exit out of the Options menu.

NOTE: *If the Ringer switch is set to off, you will not be able to adjust the Ringer pitch.*

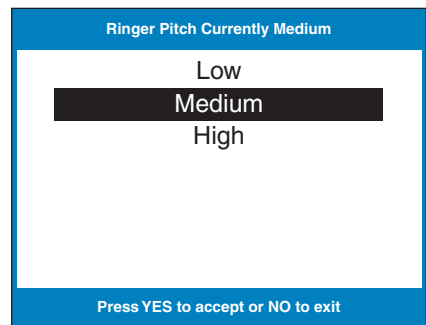
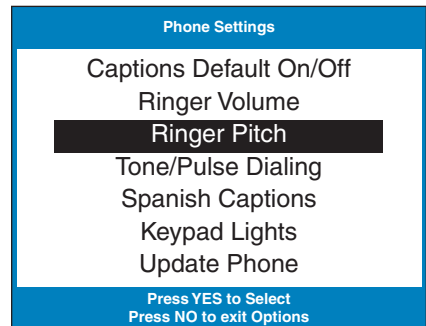
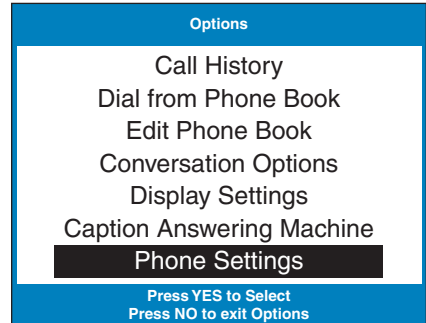

Turning the Ringer Switch On/Off

Back (top) edge view of *CapTel* 800i

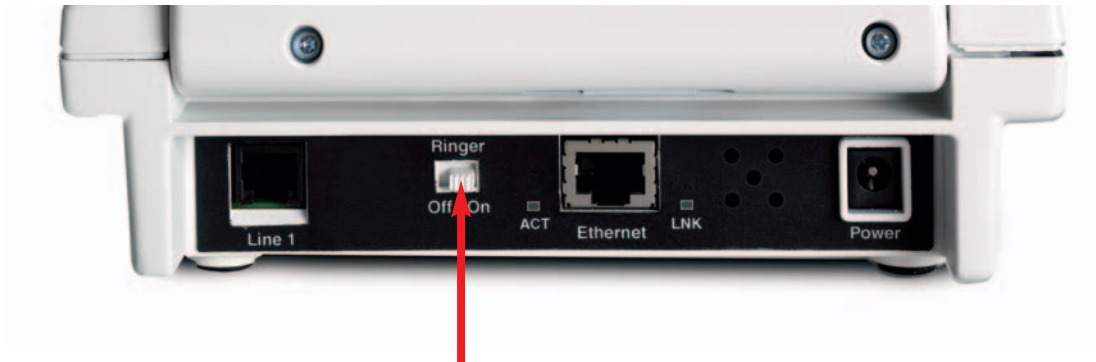









You can turn the Ringer off, so that no sound is made when your new *CapTel* phone rings. To turn the Ringer switch to ON or OFF, simply move the switch on the back (top) edge of your *CapTel* phone to **ON** or **OFF**.

This setting will remain the same until you change it again.

Setting your *CapTel* Phone for Tone/Pulse Dialing

The dialing mode of your *CapTel* 800i phone is set to Tone dialing. To set the dialing mode to Pulse dialing:

-  1. Press the **YES** button to see Options.
-  2. Press the **DOWN** button repeatedly until **Phone Settings** is highlighted.
-  3. Press the **YES** button to select.
-  4. Press the **DOWN** button repeatedly until **Tone/Pulse Dialing** is highlighted.
-  5. Press the **YES** button to select.
-  6. Press the **UP** or **DOWN** button to select **Tone Dialing** or **Pulse Dialing**.
-  7. When the dialing mode you want is highlighted, press the **YES** button to accept.
-  8. Press the **NO** button to exit out of the Options menu.

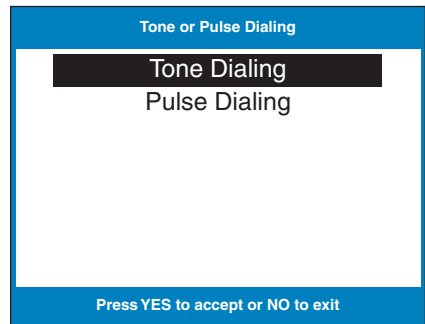
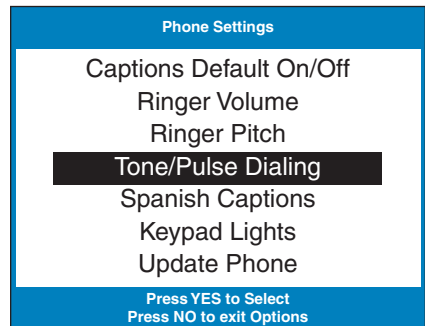
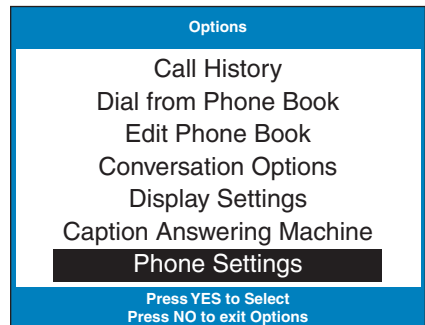

Turning on Spanish Captions

Your *CapTel* 800i phone can display captions in Spanish for Spanish-to-Spanish conversations. Setting the captions to Spanish language changes the captions only, the Options list and other phone settings will always be shown in English.

NOTE: *Spanish captioning is available for Spanish-to-Spanish conversations only. The CapTel 800i phone does not translate from English conversations to Spanish captions.*

To turn Spanish captions on:

1. With the handset hung up, press the **YES** button to see Options.
2. Press the **DOWN** button repeatedly until **Phone Settings** is highlighted.
3. Press the **YES** button to select.
4. Press the **DOWN** button repeatedly until **Spanish Captions** is highlighted.
5. Press the **YES** button to select.
6. Press the **UP** or **DOWN** button to select **Enabled** to turn on Spanish Captions or select **Disabled** to turn off Spanish Captions.

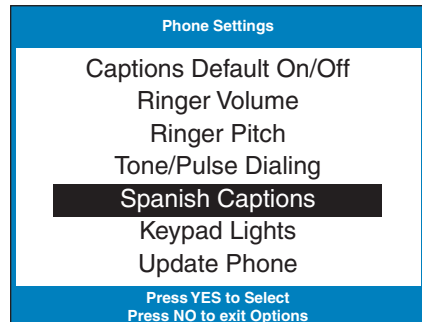
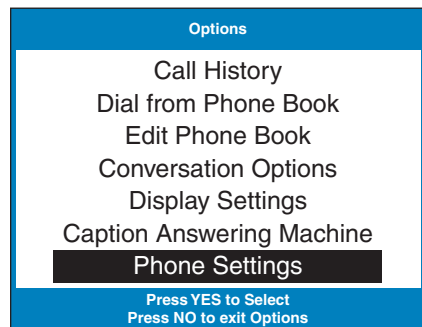



7. Press the **YES** button to accept.



8. Press the **NO** button to exit out of the Options menu.

You are now ready to make and receive calls with captions in Spanish. To make a call with Spanish language captions, lift the handset and dial the number you want to call.

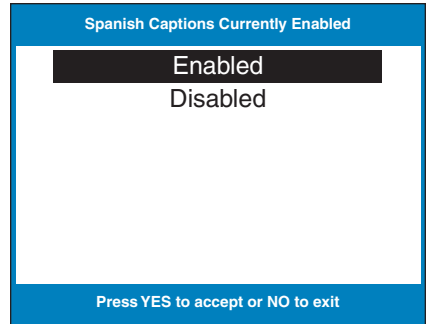









NOTE: *Spanish captions must be Enabled in order for you to receive captions in Spanish. If Spanish captions are Disabled and a Spanish-speaking person calls you, their captions will not appear in Spanish. You will need to ask them to call you back in a few minutes, after you've had a chance to set Spanish captions to Enabled.*

Spanish CapTel Customer Service: 1-866-670-9134
Spanish-to-Spanish captioning available every day from
7:00 a.m. – 11:00 p.m. CST

Turning Keypad Lights On/Off

The *CapTel* 800 dialing keypad is lit to make it easier to see the number keys. The lights on the number keypad can be turned off in the *CapTel* Options menu. When Keypad Lights Off is selected, the lights on the number keypad go off automatically whenever the *CapTel* display screen is blank (i.e., after approximately 60 seconds of non-use).

To turn the lights on the number keypad off:

-  1. Press the **YES** button to see Options.
-  2. Press the **DOWN** button until **Phone Settings** is highlighted. Press the **YES** button to select.
- 
 3. Press the **DOWN** button repeatedly until **Keypad Lights** is highlighted. Press the **YES** button to select.
- 
 4. Press the **UP** or **DOWN** button to turn Keypad Lights On or Off.
NOTE: *When Keypad Lights Off is selected, the dialing keypad lights will go off whenever the display is blank. The lights will remain on when the phone is in use.*
-  5. Press the **YES** button to select your option, or press the **NO** button to exit.
-  6. Press the **NO** button repeatedly to exit out of the Options menu.

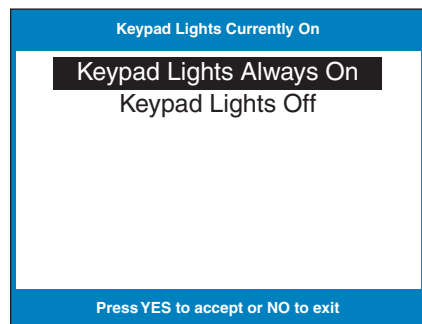
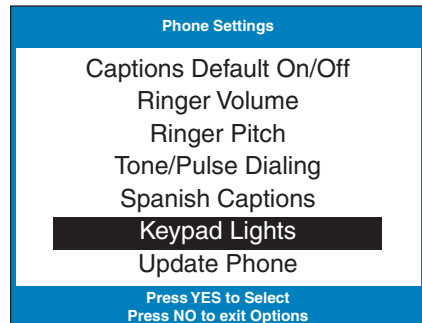
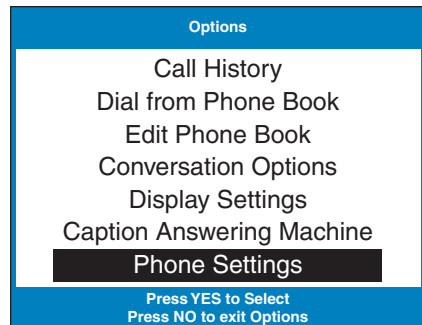

Using Call Waiting

You can use enhanced telephone features such as Call Waiting that you may have as part of your telephone service. With the *CapTel* 800i, you will see captions during your first conversation and during the second Call Waiting conversation as well.

To use Call Waiting:

1. During a conversation, listen for the beep or see (TONES) in the captions. It may indicate an incoming call with Call Waiting.
2. Inform the party you are speaking with on the initial call that you have another call on Call Waiting and ask if they would mind holding.

FLASH



3. Press the **FLASH** button to switch to the second call (you will receive captions of this call as well).

FLASH



4. Press the **FLASH** button to return to the first call if appropriate.

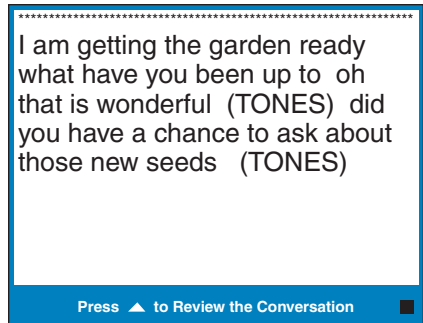

Dialing 911 with Your *CapTel* 800i

With *CapTel* 800i, calls to 911 are handled exactly the same as if you called from any other phone connected to your telephone service, plus you get captions of the call directly from the *CapTel* Captioning Service. General instructions for dialing 911 are listed below. For detailed instructions about your phone service and 911, please check with your telephone service provider.

To Dial 911:

1. Pick up handset and dial 911. Your call will be directly connected to the local emergency center for your area.
2. Make sure the Caption button is on. If not, press the Caption button to turn the captions on. You will receive captions of everything the 911 call-taker says.
3. When 911 answers, state your emergency and confirm your location.

CAPTIONS



If you turn captions on in the middle of a call to 911, there will be a brief delay before the captions begin while the *CapTel* phone connects to the Captioning Service. During that time the 911 call-taker will be able to hear everything you say. If necessary, tell the 911 call-taker you are reading captions.

Updating Your *CapTel* Phone

Occasionally, changes are made to the *CapTel* 800i software. Your phone can check whether new software is available and then perform an update as needed over the Internet connection. This process ensures you will always have the latest technology for as long as you own your *CapTel* 800i.

To update your *CapTel* 800i software:



1. With the handset hung up, press the **YES** button to see Options.



2. Press the **DOWN** arrow button repeatedly until **Phone Settings** is highlighted.



Press the **YES** button to select.



3. Press the **DOWN** arrow button repeatedly until **Update Phone** is highlighted.



Press the **YES** button to select.



4. Press the **YES** button to begin updating your phone, or press the **NO** button to exit.



5. The *CapTel* phone checks to make sure that your software is up to date. If a new software version is available, your *CapTel* phone automatically updates to the most current version, then resets itself so you are ready to make calls.

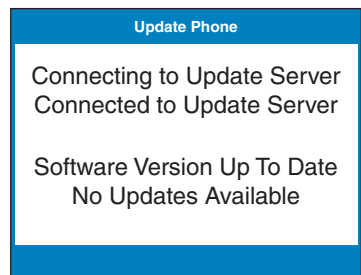
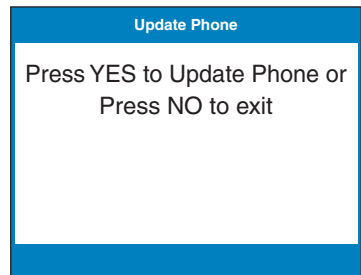
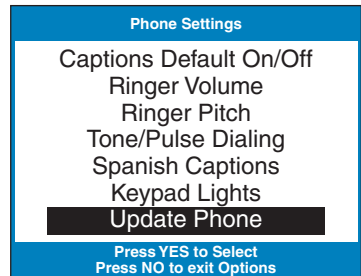
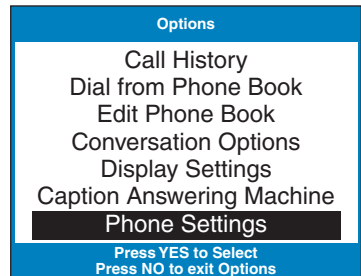

Problem Solving

My *CapTel* 800i does not ring

Check that the RINGER switch is set to ON.

Too many phones and/or computer modems in your home may exceed the “ringer equivalence number” (REN) allotted by your telephone service.

Contact your telephone service provider to verify that your service is adequate for the number of phones/devices you use.

I want to make captioned calls at work, but I don’t hear a dial tone when I pick up the handset.

If you need to dial a “9” or another number to get an outside line, then you must dial the “9” before placing your call. When programming a Speed Dial button, be sure to include the dialing prefix before the phone number.

What does “No Network Connection” prompt on my screen mean?

It means that the *CapTel* 800i is not able to send and receive data over the Internet. Check your connections again to confirm that you are connected to Internet service, and that your Internet service is working properly. If the problem persists, please contact *CapTel* Customer Service for help.

Can I use the Internet on my computer at the same time that I am on the *CapTel* 800i phone with captions?

Yes. At times, you may experience slightly slower captions. But there should be no major difficulty using both the Internet with your computer and using your *CapTel* phone at the same time.

Leaving messages on answering machines

You may begin leaving your message as soon as you see (BEEP) on the display screen or hear the recorded greeting end.

If you receive no further information, you may assume your message was recorded. If the answering machine is capable of confirming that a message was left, you will see the confirmation message on the *CapTel* display.

Using automated (touchtone) systems

With *CapTel*, you can easily navigate through automated phone menu systems (example: press “1” for sales, press “2” for shipping, etc.). You can press number buttons at anytime during a call to make selections. You do not need to wait for captions prior to pressing your selection. The captioning service continuously transcribes anything that is said over the phone, regardless of what you are saying or which buttons you press.

NOTE: *Some automated systems have very short response times which may disconnect you. If this happens, simply hang up and try the call again.*

Difficulty hearing over the *CapTel* 800i handset

- Try adjusting the volume setting by pressing the VOLUME bar. To increase the volume, press and hold the right ▲ side of the bar. Watch the status lights above the VOLUME bar to know what the setting is. See page 22.
- Try adjusting the TONE setting to enhance different frequency sounds. Press the TONE key to emphasize HIGH, MEDIUM, or LOW frequency sounds. See page 23 for details.

Display screen seems to be “stuck” at Waiting for Captions status bar. Nothing seems to be happening.

- Press the CAPTIONS button off and then on again.
- Hang up your *CapTel* 800i phone and try to place the call again.
- If you are still experiencing the problem, unplug your *CapTel* 800i from the power adapter, wait 10 seconds, then plug the power back in again. This “resets” the *CapTel* 800i, in the same way you might “reset” your computer. Try making the call again.
- Try resetting the network connection by unplugging the *CapTel* AC adapter, then turning off the Router and the Internet modem. Wait a few seconds, then turn on the modem (make sure it’s fully reset, with lights going steady). Next, turn on the Router, making sure it is fully reset. Then plug in the *CapTel* 800i AC adapter, all in that order. Wait for the blue *CapTel* logo to appear. The Captions button should be lit.
- If the problem still persists, please contact *CapTel* Customer Service for help.

CARE & MAINTENANCE

Cleaning

Never use liquid or aerosol cleaners. Unplug the *CapTel* and wipe with a damp cloth. If necessary, use a small amount of mild soap such as dishwashing soap on the cloth.

SAFETY INSTRUCTIONS

When using your *CapTel*, basic safety precautions should always be followed to reduce the risk of fire, electric shock, and injury to persons.

1. Read and understand all instructions.
2. Follow all warnings and instructions on the *CapTel*.
3. Unplug the *CapTel* from the wall outlet before cleaning. Do not use liquid or aerosol cleaners. Use a damp cloth for cleaning.
4. Do not use the *CapTel* near water, for example, near a bath tub, wash bowl, kitchen sink, laundry tub, in a wet basement or near a swimming pool.
5. Do not place the *CapTel* on an unstable cart, stand or table. The *CapTel* may fall, causing serious damage to the phone.
6. The *CapTel* should be operated only from the type of power source indicated on the marking label. If you are not sure of the type of power supply to your home, consult your dealer or local power company.
7. Do not allow anything to rest on the power cord. Do not locate the *CapTel* where people can walk on the cord.
8. Do not overload wall outlets and extension cords. This overloading can result in a fire or electric shock.
9. To reduce the risk of electric shock, do not disassemble the *CapTel*, but take it to a qualified service person when service or repair work is required. Opening or removing covers may expose you to dangerous voltages or other risks.
10. Avoid using a telephone (other than a cordless type) during an electrical storm. There is a remote risk of electric shock from lightning.
11. Pressing the button may subject the user to dangerous volume levels.
12. Unplug the *CapTel* from the wall outlet and refer servicing to qualified service personnel under the following conditions:
 - a. When the power supply cord or plug is damaged or frayed.
 - b. If liquid has been spilled into the telephone.
 - c. If the telephone has been exposed to rain or water.
 - d. If the telephone does not operate normally by following the operating instructions. Adjust only those controls that are covered by the operating instructions. Improper adjustment of other controls may result in damage and will often require extensive work by a qualified technician to restore the telephone to normal operation.
 - e. If the telephone has been dropped and/or damaged.
 - f. If the telephone exhibits a distinct change in performance.
13. Do not use the telephone to report a gas leak in the vicinity of the leak.

I N D E X

Answering a call	17	Captions	
Answering machine.....	52	button	9, 55
connecting to an external		changing color of captions.....	33
answering machine	54	saving captions after a call	28
seeing captions of answering		reviewing captions	
machine messages	53	during a call	9, 26
Assistive listening devices.....	11, 23	reviewing captions after	
using with <i>CapTel</i> 800i	11, 23	hanging up	9, 27
Audio jacks.....	11	turning captions	
Buttons	6	On/Off	9, 17, 21, 22, 25, 26
Redial.....	6, 8	seeing captions of answering	
Flash.....	6, 8, 67	machine messages	52-54
Mute.....	6, 8	seeing captions of voice	
Tone	6, 9, 23	mail messages	52, 55
Captions	6, 9, 17, 18, 19, 20, 21,	changing size of captions	31
.....	22, 26, 51, 55, 68	Conversations	
Calls	17	saving conversations	28
Making/answering calls.....	17-21	deleting conversations	29
Using Call History to see		Conversation Options	26-30
recent calls	37-39	Customer Service	
Call History.....	38	button	7, 56
reviewing Caller ID entries	38, 39	calling for help	7, 56, 65, 70
deleting Caller ID entries.....	39, 40	Customer Service hours.....	7
clearing all Caller ID entries	40	Spanish customer service	65
Call Waiting	8, 67	Dialing	
		using Speed Dial buttons.....	19, 50
		from the Phone Book.....	44
		dialing 9 in an office setting	70
		a phone number directly	18

Display Screen	Reset (problem solving).....71
adjusting the brightness.....35	Reviewing Calls.....25, 26, 27
Flash button8, 67	Set up.....12
Headsets, using with <i>CapTel</i> 800i11	requirements12
Internet	help with set up16
connecting to the Internet10, 14	using a router.....15
requirements12	Spanish
using a router.....15	captions64
Lights, on keypad66	customer service in Spanish.....65
Mute button.....8	Speed Dial buttons
Neckloop, using with.....11, 23	dialing with the Speed
Phone Book	Dial buttons51
dialing from the phone book44	adding a name/number
adding a new contact to the	to Speed Dial.....49
phone book.....42	editing a name/number in
editing names/numbers in the	Speed Dial50
phone book.....45	Telephone line12
removing a contact from the	requirements12
phone book.....47	Tone
Options	button9, 23, 71
Call History.....37	adjusting for different
Dial from Phone Book.....44	frequencies.....23, 71
Edit Phone Book45	Voice Mail
Conversation Options27-30	seeing captions of Voice
Display Settings31-36	Mail messages53
Answering Machine53	Volume
Phone Settings57	Volume bar9, 22
Redial button8	adjusting the volume 9, 22, 71

FCC Information

The *CapTel* has been tested and found to comply with the specifications for a Class B digital device pursuant to Part 15 of the FCC Rules. These limits are designed to provide reasonable protection against harmful interference in a residential installation. This equipment generates and uses radio frequency energy and if not installed and used in accordance with the instructions, may cause harmful interference to radio communications. However, there is no guarantee that interference will not occur in a particular installation.

If this equipment does cause harmful interference to radio or television reception, which can be determined by turning the equipment off and on, the user is encouraged to try to correct the interference by one or more of the following measures:

- Reorient or relocate the receiving antenna.
- Increase the separation between the *CapTel* and the receiver.
- Connect the *CapTel* to an outlet on a circuit different from that to which the receiver is connected.
- Consult the dealer or an experienced radio/TV technician for help.

This equipment complies with Part 68 of the FCC rules and the requirements adopted by the ACTA. A label is located on the underside of the *CapTel* containing, among other information, an FCC registration number, US:D8KMM06BCAPTEL800. If requested, this number must be provided to the telephone company.

A plug and jack used to connect this equipment to the premises wiring and telephone network must comply with the applicable FCC Part 68 rules and requirements adopted by the ACTA. A compliant telephone cord and modular plug is provided with this product. It is designed to be connected to a compatible modular jack that is also compliant. See installation instructions for details.

The REN is used to determine the quantity of devices which may be connected to the telephone line. Excessive RENs on the line may result in the devices not ringing in response to an incoming call. In most, but not all, areas the sum of RENs should not exceed five (5.0). To be certain of the number of devices that may be connected to a line, as determined by the total RENs, contact the local telephone company. The REN for this product is 0.6B.

Should you experience trouble with this telephone equipment, please contact:

CapTel Customer Service
450 Science Drive
Madison, WI 53711
Phone: 888-269-7477 V/TTY
Email: CapTel@CapTel.com

For repair or warranty information, please contact *CapTel* Customer Service at 1-888-269-7477 (V/TTY). If the equipment is causing harm to the telephone network, the telephone company may request that you disconnect the equipment until the problem is resolved.

This equipment cannot be used on public coin phone service provided by the telephone company. Connection to party line service is subject to state tariffs.

If the *CapTel* causes harm to the telephone network, the telephone company will notify you in advance that temporary discontinuance of service may be required. But, if advance notice is not practical, the telephone company will notify you as soon as possible. Also, you will be advised of your right to file a complaint with the FCC if you believe it is necessary.

Occasionally, your telephone company may make changes in its facilities, equipment, operation, or procedures that could affect the operation of your equipment. If so, you will be given advance notice of the change to give you an opportunity to maintain uninterrupted service.

If your home has specially wired alarm equipment connected to the telephone line, ensure the installation of the *CapTel* does not disable it. If you have questions about what will disable alarm equipment, consult your telephone company or a qualified installer.

The *CapTel* telephone does not have any user-serviceable parts. Modification or changes to the *CapTel* not expressly approved by Ultratec, Inc. can void your authority to operate the equipment.

Getting Help

If you have any questions, comments, or concerns as you use your new *CapTel* 800i, we're here to help. Use any of these ways to contact us:

CUST
SERV



CUST SERV Button

Pick up the handset and press the **CUST SERV** button to automatically speed dial directly to our helpful Customer Service team. If you are in an office setting, you may need to dial "9" first and then press the **CUST SERV** button.

On-demand help is available Monday-Friday during standard business hours.



Phone: 1-888-269-7477

FAX: (608) 204-6167



Mail: CapTel Customer Service
450 Science Drive
Madison, WI 53711



Email: CapTel@CapTel.com

Online: www.CapTel.com